

DOW UNIVERSITY OF HEALTH SCIENCES



BIDDING DOCUMENTS

Single Stage – Two Envelope Procedure

As per Rule 46 (2) of SPPRA, 2010 (Amended upto date)

**SUPPLY, FIXING, INSTALLATION &
COMMISSIONING OF 40.8Kw GRID TIED SOLAR
SYSTEM AT DOW INTERNATIONAL DENTAL COLLEGE
(DHA CAMPUS) KARACHI**

NIT # DUHS/P&D/2022/11175,

DATED: 13 OCTOBER, 2022

**OFFICE OF THE DIRECTOR PLANNING & DEVELOPMENT
DOW UNIVERSITY OF HEALTH SCIENCES,
BABA-E-URDU ROAD, BESIDES CIVIL HOSPITAL,
KARACHI**

TABLE OF CONTENTS		
A.	INSTRUCTIONS TO BIDDERS (ITB)	2
1.	Introduction	2
2.	The Bidding Procedure	3
3.	The Bidding Documents	3
4.	Preparation of Bids	4
5.	Submission of Bids	7
6.	Opening and Evaluation of Bids	8
7.	Award of Contract	15
B.	GENERAL CONDITIONS OF CONTRACT (GCC)	18
1.	Definitions	18
2.	Application	18
3.	Technical Specifications / Standards	18
4.	Use of Contract Documents and Information	19
5.	Patent Rights	19
6.	Ensuring Storage Arrangements	19
7.	Inspections, Tests and Training	19
8.	Delivery and Documents	20
9.	Insurance	20
10.	Transportation	20
11.	Incidental Services	20
12.	Warranty / Guarantee	20
13.	Payment	21
14.	Assignment	21
15.	Delays in the Bidder's Performance	21
16.	Penalties / Liquidated Damages	22
17.	Termination for Default	22
18.	Force Majeure	23
19.	Termination for Insolvency	23
20.	Termination for Convenience	23
21.	Resolution of Disputes	24
22.	Governing Language	24
23.	Applicable Law	24
24.	Notices	24
25.	Taxes & Duties	24
C:	INVITATION FOR BIDS (IFB)	25
D:	BID DATA SHEET	26
E:	SPECIAL CONDITIONS OF CONTRACT (SCC)	28
F:	SCHEDULE OF REQUIREMENTS	32
G:	TECHNICAL SPECIFICATIONS	33
H:	SAMPLE FORMS	35
1.	Performance Guarantee / Security Form	35
2.	Manufacturer's Authorization Form	36
3.	Contract Form	37
3.	Integrity Pact	38
I:	BID FORM & PRICE SCHEDULE	39
1.	Bid Form	39
2.	Price Schedules	40-42
<i>Annex: A</i>	<i>Experience of similar Supply and Installation during last 3 years</i>	43
J:	DRAWINGS	44-50

A: INSTRUCTIONS TO BIDDERS. (ITB)

1. INTRODUCTION

1 SCOPE

- 1.1 Dow University of Health Sciences, Karachi intend to purchase, **“SUPPLY, FIXING, INSTALLATION & COMMISSIONING OF 40.8kW GRID TIED SOLAR SYSTEM AT DOW INTERNATIONAL DENTAL COLLEGE, DHA CAMPUS KARACHI”**. Through Bidding Single Stage Two Envelope Procedure as per SPPRA Rules-2010 (Amended upto date).

2. ELIGIBLE BIDDERS

- 2.1. This Invitation for Bids is open to all Engineering firms / contractors Authorized Agents / Sole Distributors within Pakistan, having valid authorization certificate of the product.
- 2.2. Bidders should not be associated, or have been associated in the past, directly or indirectly, with a firm or any of its affiliates which have been engaged by the University to provide consulting services for the preparation of the design, specifications, and other documents to be used for the procurement of the goods to be purchased under this Invitation for Bids.
- 2.3. Government-owned enterprises may participate only if they are legally and financially autonomous, if they operate under commercial law, and if they are not a dependent agency of the Federal Govt. or Provincial Govt.
- 2.4. Bidder should not be eligible to bid if they are under a declaration of ineligibility for corrupt and fraudulent practices issued by any Government organization in accordance with sub **clause 35.1**.

3. ELIGIBLE GOODS

- 3.1 All goods and related services to be supplied under the contract shall have their origin in eligible source countries and all expenditures made under the contract shall be limited to such goods and services. For this purpose, the term “Goods” includes any Goods that are the subject of this Invitation for Bids and the term “Services” shall include related services such as transportation, insurance etc. **The “Origin” means the place where the “goods” are mined, grown, or produced, or the place from which the “related services” are supplied.** Goods are produced through manufacturing or processing, or substantial and major assembly of ingredients / components, a commercially recognized product results that is substantially different in basic characteristics or in purpose or utility from its components.

2. THE BIDDING PROCEDURE

Single Stage - Two Envelope Procedure under Rule 46(2) of SPPRA Rules, 2010
(Amended upto date).

- (a) Bid shall comprise a single package containing two separate envelopes. Each envelope shall contain separately the financial proposal and the technical proposal;
- (b) Envelopes shall be marked as “FINANCIAL PROPOSAL” and TECHNICAL PROPOSAL” in bold and legible letters to avoid confusion;
- (c) Initially, only the envelope marked “TECHNICAL PROPOSAL” shall be opened;
- (d) Envelope marked as “FINANCIAL PROPOSAL” shall be retained in the custody of the procuring agency without being opened;
- (e) Procuring agency shall evaluate the technical proposal in a manner prescribed in advance, without reference to the price and reject any proposal which does not conform to the specified requirements;
- (f) No amendments in the technical proposal shall be permitted during the technical evaluation;
- (g) Financial proposals of technically qualified bids shall be opened publicly at a time, date and venue announced and communicated to the bidders in advance;
- (h) Financial proposal of bids found technically non-responsive shall be returned un-opened to the respective bidders; and
- (i) Bid found to be the lowest evaluated or best evaluated bid shall be accepted.
- (j) The bids shall be opened in the presence of bidders or their authorized representative at the prescribed time, date and venue.

3. THE BIDDING DOCUMENTS

CONTENTS OF BIDDING DOCUMENTS

3.1 The Bidding Documents:

In addition to the Invitation for Bids (IFB) / Tender Notice, the bidding documents include:

- i. Instructions to Bidders (ITB);
- ii. General Conditions of Contract (GCC);
- iii. Special Conditions of Contract (SCC);
- iv. Schedule of Requirements;
- v. Technical Specifications;
- vi. Contract Form;
- vii. Manufacturer's Authorization Form;
- viii. Performance Guarantee Form;
- ix. Bid Form; and
- x. Price Schedules.

3.2 In case of discrepancies between the Invitation for Bids (IFB) / Tender Notice and the Bidding Documents, the Bidding Documents shall take precedence

3.3 The bidders are expected to examine all instructions, forms, terms, and specifications in the bidding documents. Failure to furnish complete information required in the bidding documents or to submit a bid not substantially responsive to the bidding documents may result in rejection.

AMENDMENT / CLARIFICATION OF BIDDING DOCUMENTS

3.4 An interested bidder, who has obtained bidding documents, may request for clarification of contents of the bidding document in accordance with the Rule 23(1) of SPPRA Rules, 2010 (Amended upto date).

3.5 At any time prior to the deadline for submission of bids, the Procuring Agency may, for any reason, whether at its own initiative or in response to a clarification requested by a prospective Bidder, modify the bidding documents by amendment.

3.6 All prospective bidders that have received the bidding documents will be notified the amendment(s) in writing, which will be binding on them.

3.7 In order to allow prospective bidders reasonable time to take the amendment(s) into account in preparing their bids, the Procuring Agency may, at its discretion, extend the deadline for submission of the bids.

4. PREPARATION OF BIDS

LANGUAGE OF BID

4.1 Preparation of Bids

The bid prepared by the bidder, as well as all correspondence and documents relating to the bid exchanged by the bidder and the Procuring Agency shall be in English. Supporting documents and printed literature furnished by the bidder may be in another language provided these are accompanied by an accurate translation of the relevant passages in English, in which case for purposes of interpretation of the Bid, the translated version shall prevail.

DOCUMENTS COMPRISING THE BID

4.2 The bid prepared by the Bidder shall comprise the following:

- (a) Bid Form;
- (b) Price Schedule;
- (c) Documentary evidence to the effect that the Bidder is eligible to bid and is qualified to perform the Contract if its bid is accepted;
- (d) Documentary evidence to the effect that the goods to be supplied by the Bidder are eligible goods and related services as defined in clause-3 and conform to the bidding documents; and Bid Security.

BID PRICES

4.3 The prices and discounts quoted by the Bidder in the Bid Form and in the Price Schedules shall conform to the requirements specified below.

- 4.4 All items in the Schedule of Supply must be listed and priced separately in the Price Schedules. If a Price Schedule shows items listed but not priced, their prices shall be assumed to be included in the prices of other items. Items not listed in the Price Schedule shall be assumed not to be included in the Bid.
- 4.5 The price to be quoted in the Bid Form shall be the total price of the Bid excluding any discounts offered.
- 4.6 The Bidder shall quote any unconditional discounts and the methodology for their application in the Bid Form.
- 4.7 Prices proposed in the Price Schedule Forms for Goods / services, shall be disaggregated, when appropriate. This disaggregation shall be solely for the purpose of facilitating the comparison of Bids by the Procuring Agency. This shall not in any way limit the Procuring Agency's right to contract on any of the terms offered:
- a) Price Schedule For Goods offered from within the Procuring Agency's country:
- i. Detailed Specification of Stores
 - ii. Model / Cat No.
 - iii. Name of Manufacturer.
 - iv. Country of Origin
 - v. Quantity of Stores
 - vi. Unit
 - vii. The unit price of the goods quoted on delivered duty paid (DDP) basis, including all customs duties and sales and other taxes already paid or payable on the components and raw material used in the manufacture or assembly of goods, or on the previously imported goods of foreign origin;
 - viii. If there is no mention of taxes, the offered/quoted price will be considered as inclusive of all prevailing taxes/duties. The benefit of exemption from or reduction in the GST or other taxes during the contract period shall be passed on, excluding GST (as University is exempted from GST), to the Procuring Agency; and
 - ix. The total price for the item.
- 4.8 Final Prices quoted by the Bidder shall be fixed during the Bidder's performance of the Contract and not subject to variation on any account. A Bid submitted with an adjustable price quotation shall be treated as nonresponsive and shall be rejected.
- 4.9 If it was proved during the contract period that bidder has supplied the contracted item(s) to any other purchasing agency in Pakistan at the prices lower than the contracted prices, the balance amount will be deducted from the bill and / or security deposit of the bidder.

BID CURRENCIES

- 4.10 Prices shall be quoted in Pak Rupees unless otherwise specified in the Bid Data Sheet.

DOCUMENTS ESTABLISHING BIDDER'S ELIGIBILITY AND QUALIFICATION

- 4.11 The documentary evidence of the Bidder's qualifications to perform the contract if its bid is accepted shall establish to the Procuring Agency's satisfaction:
- (a) that, in the case of a Bidder offering to supply goods under the contract which the Bidder did not manufacture or otherwise produce, the Bidder has been duly authorized by the goods' Manufacturer or producer to supply the goods in the Procuring Agency's country;
 - (b) that the Bidder has the financial, technical, and production capability necessary to perform the contract;
 - (c) that, in the case of a Bidder not doing business within the Procuring Agency's country, the Bidder is or will be (if awarded the contract) represented by an Agent in that country equipped, and able to carry out the Bidder's maintenance, repair, and spare parts-stocking obligations prescribed in the Conditions of Contract and/or Technical Specifications; and
 - (d) That the Bidder meets the evaluation & qualification criteria of bidding document.

DOCUMENTS ESTABLISHING GOODS' ELIGIBILITY AND CONFORMITY TO BIDDING DOCUMENTS

- 4.12 Pursuant to ITB Clause 8, the Bidder shall furnish, as part of its bid, documents establishing the eligibility and conformity to the bidding documents of all goods and services which the Bidder proposes to supply under the contract.
- 4.13 The documentary evidence of the eligibility of the goods and services shall consist of a statement in the Price Schedule of the country of origin of the goods and services offered which shall be confirmed by a certificate of origin issued at the time of shipment.
- 4.14 The documentary evidence of conformity of the goods and services to the bidding documents may be in the form of literature, drawings, and data, and shall consist of:
- (a) a detailed description of the essential technical and performance characteristics of the goods; and
 - (b) an item-by-item commentary on the Procuring Agency's Technical Specifications demonstrating substantial responsiveness of the goods and services to those specifications, or a statement of deviations and exceptions to the provisions of the Technical Specifications.
- 4.15 For purposes of the commentary to be furnished pursuant to ITB Clause 12.3(b) above, the Bidder shall note that standards for workmanship, material, and equipment, as well as references to brand names or catalogue numbers designated by the Procuring Agency in its Technical Specifications, are intended to be descriptive only and not restrictive. The Bidder may substitute alternative standards, brand names, and/or catalogue numbers in its bid, provided that it demonstrates to the Procuring Agency's satisfaction that the substitutions ensure substantial equivalence to those designated in the Technical Specifications.

BID SECURITY

- 4.16 The Bidder shall furnish, as part of its proposal, a Bid Security in the amount and currency specified in the Bid Data Sheet and SCC. Unsuccessful bidders' Bid Security will be returned soon after approval of the successful Bidder. The successful Bidder's Bid Security will be discharged upon signing of contract and furnishing the Performance Security bond, duly guaranteed by a scheduled bank.
- 4.17 The Bid Security shall remain valid for a period of 28 days beyond the bid validity period.
- 4.18 The Bid Security is required to protect the Procuring Agency against the risk of Bidder's conduct, which would warrant the Security's forfeiture;
- 4.19 The Bid Security may be forfeited:
- a. if a Bidder withdraws its bid during the period of bid validity; or
 - b. in the case of a successful Bidder, the Bidder fails:
 - i). to sign the Contract; or
 - ii). to complete the supplies / services in accordance with the general Conditions of contract.

BID VALIDITY

- 4.20 Bids shall remain valid for 90 days from the date of its opening. A bid valid for a shorter period shall be treated as non-responsive and rejected.
- 4.21 The Procuring Agency shall ordinarily be under an obligation to process and evaluate the bids within the stipulated bid validity period. However, for any reasons to be recorded in writing, if an extension is considered necessary, all those who have submitted their bids shall be asked to extend their respective bid validity period.

ALTERNATIVE BIDS

- 14.22 Unless otherwise indicated in the BDS, alternative bids shall not be considered.

5. SUBMISSION OF BIDS

SEALING AND MARKING OF BIDS

- 5.1 The envelopes shall:
- (a) bear the name and address of the Bidder;
 - (b) bear the specific identification Name and Number of this bidding process indicated in the Bid Data Sheet; and
 - (c) bear the Procuring Agency's name and a statement: "**DO NOT OPEN BEFORE,**" the time and date specified in the Bid Data Sheet.
- 5.2 If all envelopes are not sealed and marked as required, the Procuring Agency will assume no responsibility for the misplacement or premature opening of the bid.

DEADLINE FOR SUBMISSION OF BIDS

- 5.3 Bids must be submitted by the bidders and received by the Procuring Agency at the specified address not later than the time and date specified in the Bid Data Sheet.
- 5.4 The Procuring Agency may, at its convenience, extend this deadline for submission of bids by amending the bidding documents in which case all rights and obligations of the Procuring Agency and the Bidders previously subject to the deadline will thereafter be subject to the deadline as extended.

LATE BID

- 5.5 Any bid received by the Procuring Agency after the deadline for submission of bids prescribed by the Procuring Agency shall not be entertained and returned unopened to the bidder.

WITHDRAWAL OF BIDS

- 5.6 The Bidder may after its submission withdraw prior to the expiry of the deadline prescribed for submission of bids.

6. OPENING AND EVALUATION OF BIDS

OPENING OF BIDS BY THE PROCURING AGENCY

- 6.1 The Procuring Agency will open all bids in the presence of bidders' representatives who choose to attend, at the time, on the date, and at the place specified in the Bid Data Sheet. The bidders' representatives who are present shall sign a register evidencing their attendance.
- 6.2 The bidders' names, bid modifications or withdrawals, bid prices, discounts, and the presence or absence of requisite bid security and such other details as the Procuring Agency, at its discretion, may consider appropriate, will be announced at the opening. No bid shall be rejected at bid opening, except for late bids, which shall be returned unopened to the Bidder pursuant to ITB Clause 18.
- 6.3 Bids that are not opened and read out at bid opening shall not be considered further for evaluation, irrespective of the circumstances. Withdrawn bids will be returned unopened to the bidders.

CLARIFICATION OF BIDS

- 6.4 During evaluation of the bids, the Procuring Agency may, at its discretion, ask the Bidder for a clarification of its bid. The request for clarification and the response shall be in writing, and no change in the prices or substance of the bid shall be sought, offered, or permitted.

PRELIMINARY EXAMINATION

- 6.4 The Procuring Agency will examine the bids to determine whether they are complete, whether any computational errors have been made, whether required sureties have been furnished, whether the documents have been properly signed, and whether the bids are generally in order.

- 6.5 Arithmetical errors will be rectified on the following basis. If there is a discrepancy between the unit price and the total price that is obtained by multiplying the unit price and quantity, the unit price shall prevail, and the total price shall be corrected. If the Supplier does not accept the correction of the errors, its bid will be rejected, and its bid security may be forfeited. If there is a discrepancy between words and figures, the amount in words will prevail.
- 6.6 The Procuring Agency may waive any minor informality, nonconformity, or irregularity in a bid which does not constitute a material deviation, provided such waiver does not prejudice or affect the relative ranking of any Bidder.
- 6.7 Prior to the detailed evaluation, pursuant to ITB Clause 23 the Procuring Agency will determine the substantial responsiveness of each bid to the bidding documents. For purposes of these Clauses, a substantially responsive bid is one which conforms to all the terms and conditions of the bidding documents without material deviations. Deviations from, or objections or reservations to critical provisions, such as those concerning Bid Security, Applicable Law, and Taxes and Duties, will be deemed to be a material deviation. The Procuring Agency's determination of a bid's responsiveness is to be based on the contents of the bid itself without recourse to extrinsic evidence.
- 6.8 If a bid is not substantially responsive, it will be rejected by the Procuring Agency and may not subsequently be made responsive by the Bidder by correction of the nonconformity.

EVALUATION AND COMPARISON OF BIDS

- 6.9 The Procuring Agency will evaluate and compare the bids which have been determined to be substantially responsive, pursuant to ITB Clause 22.
- 6.10 The Procuring Agency's evaluation of a bid will be on delivered duty paid (DDP) basis inclusive of prevailing duties/taxes/levies and will exclude any allowance for price adjustment during the period of execution of the contract, if provided in the bid.
- 6.11 The Procuring Agency's evaluation of a bid will take into account, in addition to the bid price quoted, one or more of the following factors, and quantified in ITB Clause 24:
- a) **Incidental costs**
Incidental costs provided by the bidder will be added by Procuring Agency to the bid price at the final destination.
 - b) **Delivery schedule offered in the bid**
The goods covered under this invitation are required to be delivered / shipped within an acceptable range of weeks specified in the Schedule of Requirement.
 - c) **Deviations in payment schedule from that specified in the Special Conditions of Contract**
Bidders shall state their bid price for the payment schedule outlined in the SCC. Bids will be evaluated on the basis of this base price. Bidders are, however, permitted to state an alternative

payment schedule and indicate the reduction in bid price they wish to offer for such alternative payment schedule. The Procuring Agency may consider the alternative payment schedule offered by the selected Bidder.

6.12 For the purpose of comparison of bids quoted in different currencies, price shall be converted into Pakistani Rupees. The rate of exchange shall be the selling rate prevailing seven working days before the date of opening of the bids, as notified by the National Bank of Pakistan (NBP) / State Bank of Pakistan (SBP).

QUALIFICATION / EVALUATION CRITERIA

A. QUALIFICATION REQUIREMENTS

S#	Qualification Criteria	Requirement
1.	Compliance to the Technical Specifications. The bidder is required to provide the relevant document such as Sketches, Drawings, Catalogues, Brochures, Technical Data Sheet duly highlighting the complete technical specifications of the offered goods along with the dimensions and details of material.	Mandatory
2.	Technical Proposal on Bidder's Letterhead	Mandatory
3.	Item-wise / Feature-wise product compliance / deviation sheet / statement.	Mandatory
4.	Valid Manufacturer Authorization in accordance with ITB Clause 11.1(a). Only manufacturer and its sole / authorized agent can quote the goods, no sub distributors / spot authorized agent is allowed to bid.	Mandatory
5.	Copy of CNIC of signatory of the Bid Forms	Mandatory
6.	Complete Bidding Document, duly signed and stamped on its each/every page as acceptance of all terms & conditions	Mandatory
7.	Compliance to bid validity period	Mandatory
8.	Compliance to payment terms and conditions	Mandatory
9.	Compliance to the delivery schedule	Mandatory
10.	Valid General Sales Tax (GST-FBR) Registration with Active Tax Payer Status on FBR website (<i>for supply of goods</i>)	Mandatory
11.	Valid Income Tax (FBR) Registration with Active Tax Payer Status on FBR website	Mandatory
12.	Professional Tax Certificate	Mandatory
13.	Original Tender Purchase Receipt / Pay Order of Tender Fee	Mandatory
14.	Affidavit on stamp paper of Rs. 100/- duly notarized to the effect that: i. The bidder is neither blacklisted nor suspended by any National / International, including Provincial and Federal Government. ii. Any director or owner of the bidding company is not awarded any punishment from any Court of Law. iii. Bidder has submitted the correct and complete information along with the bid/offer. If any document / information is found forged / engineered / fake / bogus at any stage, the bidder may be declared as Blacklisted in accordance with law and the performance guarantee and payment, if any may be forfeited.	Mandatory

15.	The Bid Form & Price Schedule(s) shall be inserted in the Financial Proposal. However, a copy of the same shall be inserted in the Technical Proposal after hiding the amount.	Mandatory
16.	Envelopes shall be marked as “FINANCIAL PROPOSAL” and TECHNICAL PROPOSAL” in bold and legible letters to avoid confusion; one (1) original and one (1) copy. The original and all copy of the Technical proposal shall be typed or written in indelible ink (in the case of copies, Photostats are also acceptable) and shall be signed by a person or persons duly authorized to sign on behalf of the bidder. Original & copies of the document should be separately clearly marking each “ORIGINAL BID” and “COPY OF BID,” as appropriate. In the event of any discrepancy between them, the original shall govern. the soft copy of technical proposal only should also be provided in the form of USB showing the name of the company	Mandatory
18.	Bid Security shall be inserted in the Financial Proposal. However, a copy of the same shall be inserted in the Technical Proposal after hiding the amount.	Mandatory
20.	Company Profile	Mandatory
22.	During the last three (3) years bidder had completed (01) project / contract for supplying, fixing, installation, & commissioning the quoted for the physical verification of quality of offered products (valid documentary evidence (contract award / purchase order to be attached).	Mandatory
23.	Average annual turnover (total income) in preceding 3 years should not be less than Rs. 10 million demonstrated through audited annual financial statements / income tax returns / original bank certificate.	Mandatory
24.	Bidder must have the valid licensed Electrical supervisor	Mandatory

B. CRITERIA FOR BID EVALUATION

i. Technical Proposal Evaluation:

- a) The bids disqualified / not responsive to the **MANDATORY QUALIFICATION CRITERIA** provided at ITB Clause 24(A) shall not be eligible for further Technical Evaluation.
- b) Conditional Bids, Telegraphic Bids, Bids not accompanied by Bid Security of required amount and form, bids received after specific date and time and bids of Black Listed firms shall be treated as rejected / non-responsive.
- c) The bids shall be evaluated and compared on **ITEMIZED BASIS** reflected in the Section: G – Technical Specifications.
- d) **Bids are invited as per Single Stage – Two Envelope Procedure** in accordance with sub rule 2 of rule 46 of the Sindh Public Procurement Rules, 2010 (Amended upto date). In case, any bidder encloses the financial bid within the technical bid, the same shall be rejected summarily.
- e) Only those Financial Bids / Proposals will be announced / considered which were technically qualified by the Engineer.
- f) Bidders achieving **minimum 70% points / marks** will be considered only for further process besides compliance of all mandatory clauses. Documentary evidence must be attached in support of your claim.
- g) Based on the record / documentary evidence submitted by the bidders, each firm shall be technically evaluated as per following merit point system for weighing evaluation factors / criteria.

ELIGIBILITY CRITERIA

S.NO	DESCRPTION	TOTAL MARKS	MARKS OBTAINED	REMARKS	ATTACHMENT OF RELEVANT EVIDENCE IN EACH CASE IS MANDATORY.IN CASE OF NON COMPLIANCE NO MARK WILL BE AWARDED	EVIDENCE ATTACHED AS
1	YEARS IN BUSINESS IN THE REQUISITE FIELD (AS A SUPPLIER, FIXING, INSTALLATION & COMMISSIONING OF SOLAR SYSTEMS)	10		5 YEAR AND ABOVE	NTN CERTIFICATE IS REQUIRED TO BE ENCLOSED	
		7		3 YEAR AND ABOVE		
		5		2 YEAR		
2	ELECTRICAL LICENSE OF BIDDER	20		YES	DOCUMENTARY PROOF TO BE ATTACHED.	
		0		NO		
4	PEC REGISTRATION CATEGORY WITH SPECIALIZATION CODES OF EE04, EE11 OF BIDDER	10		C5 OR ABOVE WITH MENTIONED CODES	DOCUMENTARY PROOF TO BE ATTACHED.	
		5		C6		
5	COUNTRY OF ORIGIN OF INVERTERS	10		European/ TOP 6 rated CHINA	DOCUMENTARY PROOF TO BE ATTACHED	
		7		ANY OTHER		
6	AUTHORIZED DISTRIBUTOR OF INVERTER FROM THE MANUFACTURER	10		YES	DOCUMENTARY PROOF TO BE ATTACHED.	
		0		NO		
7	IMPORTED ITEMS DELIVERY TIME	10		READY STOCK	DOCUMENTARY PROOF TO BE ATTACHED	
		5		WITHIN 45 DAYS		

8	SERVICE CENTER AND TRAINED ENGINEER	10	AVAILABLE IN KARACHI	DOCUMENTARY PROOF TO BE ATTACHED
		0	NOT AVAILABLE	
9	EXPERIENCE OF SIMILAR PROJECTS	20	5 OR MORE	Copy of Work order / PO / agreement / Satisfactory Performance Certificates /Invoices/other related documents must be attached for points.
		10	LESS THAN 4	
TOTAL MARKS		100	QUALIFIED / DISQUALIFIED	

NOTE:

- 1 ATTACHMENT OF RELEVANT EVIDENCE IN EACH ABOVE REQUISITE IS MANDATORY. IN CASE OF NON-PROVISION OF EVIDENCE IN ANY OF THE REQUISITE, NO MARKS WILL BE AWARDED.
- 2 ACQUIRING OF 70% MARKS OF THE TOTAL SCORE WILL MAKE THE BIDDER QUALIFY IN ELIGIBILITY CRITERIA.

ii. **FINANCIAL PROPOSAL EVALUATION:**

- a) Technically qualified/successful bidder(s) shall be eligible for Financial Proposal(s). The Financial bids shall be opened in the presence of the Bidders at the scheduled date, time and venue communicated in advance.
- b) Financial Bids / Proposals of Technically disqualified / rejected / nonresponsive bidders will not be opened and sealed envelope shall be returned to the bidder.
- c) Only those item's Financial offer will be announced / considered which were technically qualify by the Engineer. Bidders are advised to give separate financial sealed envelope (s) of every quoted item and should mention the name of the item and tender serial number on the front of the sealed envelope in **BOLD and legible letters** to avoid confusion, otherwise, the Financial Proposal Envelope will be opened on qualified item basis and it will not be challenged by the bidder that procuring agency has opened the Financial Proposal of the disqualified items besides qualified items.
- d) Bids not accompanied by the Bid Security of required amount and form shall be rejected.
- e) Procuring Agency shall not be responsible for any erroneous calculation of taxes and all differences arising out shall be fully borne by the Successful Bidder.
- f) For the purpose of comparison of bids quoted in different currencies (if applicable), price shall be converted into Pakistani Rupees. The rate of exchange shall be the selling rate prevailing seven working days before the date of opening of the bids, as notified by the National Bank of Pakistan (NBP) / State Bank of Pakistan (SBP).

CONTACTING THE PROCURING AGENCY

- 6.13 No bidder shall contact the Procuring Agency on any matter relating to its bid, from the time of the bid opening to the time the Contract is awarded. If any bidder wishes to bring additional information to the notice of the Procuring Agency, it may do so in writing.
- 6.14 Any direct or indirect effort by a bidding firm to influence the Procuring Agency during the process of selection of a bidder or award of contract may besides rejection of its bid result into its disqualification from participation in the Procuring Agency's future bids.

REJECTION OF BIDS

- 6.15 Notwithstanding anything stated here-before after the Procuring Agency may reject any or all bids at any time prior to the acceptance of a bid. The Procuring Agency may upon request, communicate to a bidder, the grounds for its rejection, but shall not be under obligation to justify those grounds.

RE-BIDDING

- 6.16 If the Procuring Agency has rejected all bids, it may move for a re-bidding or may seek any alternative method of procurement under the provisions of the prevailing Rules.

ANNOUNCEMENT OF EVALUATION REPORT

- 6.17 The Procuring Agency will announce the Evaluation Report and the resultant acceptance or rejection of bids at least three days prior to the award of procurement contract.

7. AWARD OF CONTRACT

ACCEPTANCE OF BID AND AWARD CRITERIA

- 7.1 The bidder with lowest evaluated bid under clause 22, 23 & 24, if not in conflict with any other law, rules, regulations or policy of the Government, will be awarded the contract within the original or extended period of bid validity.

PROCURING AGENCY'S RIGHT TO VARY QUANTITIES

- 7.2 The Procuring Agency reserves the right to increase or decrease the quantity of stores originally specified in the Price Schedule and Schedule of Requirements without any change in unit price or other terms and conditions.

LIMITATIONS ON NEGOTIATIONS

- 7.3 The Procuring Agency reserves the right to hold negotiation of delivery schedule or completion schedule for all the items or any item.

- 7.4 Negotiations will not be used to change substantially:
- i. the technical quality or details of the requirement, including the tasks or responsibilities of the bidder or the performance of the goods;
 - ii. the terms and conditions of the Contract and;
 - iii. anything affecting the crucial or deciding factors in the evaluation of the proposals / bid and / or selection of successful bidder.

NOTIFICATION OF AWARD

- 7.5 Prior to the expiry of the original or extended period of bid validity, the successful bidder will be informed in writing of acceptance of its bid by the Procuring Agency.

SIGNING OF CONTRACT

- 7.6 While conveying acceptance of bid to the successful bidder, the Procuring Agency will send the bidder Contract Form provided in the bidding documents, incorporating all points of agreement between the Parties.
- 7.7 Within thirty (30) days of receipt of the Contract Form, the successful Bidder and the Procuring Agency will sign and date the Contract on legal stamp paper valuing 0.35% of the value of contract, (cost shall be borne by the bidder). In case the successful Bidder, after completion of all codal formalities, shows inability to sign the Contract, its Bid Security shall be forfeited. The firm may also be blacklisted from taking part in any future bidding of Procuring Agency for a period upto five Years. In such a situation, the Procuring Agency may make the award to the next lowest evaluated responsive bidder or move for re- bid.

PERFORMANCE SECURITY / GURANTEE

- 7.8 The successful Bidder shall furnish Performance Security. Upon submission of Performance Security, the Bid Security will be returned to the Bidder. The amount of Performance Security is specified at Bid Data Sheet.
- 7.9 Failure of the successful Bidder to comply with any of the requirements specified in this document shall be considered as sufficient grounds for the annulment of the award and forfeiture of the Bid Security, in which event the Procuring Agency may make the award to the next lowest evaluated Bidder at the risk and cost of the former.

CORRUPT OR FRAUDULENT PRACTICES

- 7.10 The Procuring Agency and the Bidders / Manufacturers / Contractors are expected to observe the highest standard of ethics during the procurement and execution of the Contract. In pursuance of this policy, the relevant terms / phrases as may apply are defined below:
- (i) "corrupt practice" means the offering, giving, receiving or soliciting of anything of value to influence the action of a public official in the procurement process or in Contract execution; and

(ii) "fraudulent practice" means a misrepresentation of facts in order to influence a procurement process or the execution of a Contract to the detriment of the Procuring Agency, and includes collusive practice among Bidders (prior to or after bid submission) designed to establish bid prices at artificial noncompetitive levels and to deprive the Procuring Agency of the benefits of free and open competition;

7.11 The Procuring Agency will take all possible administrative / legal measures if it is found that the Bidder recommended for award was / is engaged in corrupt or fraudulent practice(s) before or after signing of the contract resulting into the conviction of the proprietor under criminal case besides blacklisting of the firm either indefinitely or for such period of time as may be determined by the Procuring Agency.

7.12 Will declare a firm ineligible, either indefinitely or for a stated period of time, for the award of a Contract if it, at any time, determines that the firm has engaged in corrupt or fraudulent practices in competing for or in executing a Contract.

B: GENERAL CONDITIONS OF CONTRACT (GCC)

1. DEFINITIONS

1.1 In this Contract, the following terms shall be interpreted as indicated:

- (a) "The Contract" means the agreement entered into between the Procuring Agency and the Bidder, as recorded in the Contract Form signed by the Parties, including all attachments and appendices thereto and all documents incorporated by reference therein. .
- (b) "The Contract Price" means the price payable to the Bidder under the Contract for the full and proper performance of its Contractual obligations.
- (c) "Goods" means all of the commodities, raw material, furniture, fixture, machinery and equipment, and/or other materials that the Supplier is required to supply to the Procuring Agency under the Contract.
- (d) "Related Services" means the services incidental to the supply of the goods, such as insurance, installation, fixations, training and initial maintenance, printing of special instructions on the label and packing, design and logo of the Procuring Agency, transportation of goods up to the desired destinations and other such obligations of the Bidder covered under the Contract.
- (e) "GCC" means the General Conditions of Contract contained in this section.
- (f) "SCC" means the Special Conditions of Contract.
- (g) "The Procuring Agency" means the Dow University of Health Sciences, Karachi.
- (h) "The Bidder" means the individual or firm supplying the goods under this Contract.
- (i) "Day" means official working day excluding national holidays.

2. APPLICATION

2.1 These General Conditions shall apply to the extent that they are not inconsistent with provisions of other parts of the Contract.

3. TECHNICAL SPECIFICATIONS / STANDARDS

3.1 The Goods supplied under this Contract shall conform to the standards mentioned in the Technical Specifications, and, when no applicable standard is

mentioned, to the authoritative standards appropriate to the Goods' country of origin. Such standards shall be the latest issued by the concerned institution.

4. USE OF CONTRACT DOCUMENTS AND INFORMATION

- 4.1 The Bidder shall not without the Procuring Agency's prior written consent, disclose the Contract, or any provision thereof, or any specification, plan, drawing, pattern; sample, or information furnished by or on behalf of the Procuring Agency in connection therewith, to any person other than a person employed by the Bidder in the performance of the Contract. Disclosure to such employed person shall be made in confidence and shall extend only, as far as may be necessary, to such performance and not further or otherwise.
- 4.2 Any document, other than the Contract itself, shall remain the property of the Procuring Agency and shall be returned (all copies) on completion of the Bidder's performance under the Contract.
- 4.3 The Bidder shall permit the Procuring Agency to inspect the Bidder's accounts and records relating to the performance of the Supplies.

5. PATENT RIGHTS

- 5.1 The Bidder shall indemnify the Procuring Agency against all third-party claims of infringement of patent, trademark, or industrial design rights arising from use of the Goods or any part thereof in the country.

6. ENSURING STORAGE ARRANGEMENTS

- 6.1 To ensure storage arrangements for the intended supplies, the Bidder shall inform the Procuring Agency at least two weeks prior to the arrival of the consignments at its store/warehouse. However, in case no space is available at its store/warehouse at the time of supply, the Procuring Agency shall, seven days prior to such a situation, inform the Bidder, in writing, of the possible time-frame of availability of space by which the supplies could be made. In case the Bidder abides by the given time frame, he will not be penalized for delay.

7. INSPECTIONS, TESTS & TRAINING

- 7.1 The Procuring agency or its representative(s) shall have the right to inspect and/or to test the Goods to confirm their conformity to the Contract specifications at no extra cost to the Procuring agency. SCC and the Technical Specifications shall specify what inspections and tests the Procuring agency requires and where they are to be conducted. The Procuring agency shall notify the Supplier in writing, in a timely manner, of the identity of any representatives retained for these purposes.
- 7.2 The inspections and tests may be conducted on the premises of the Supplier, at point of delivery, and/or at the Goods' final destination. If conducted on the premises of the Supplier, all reasonable facilities and assistance, including access to drawings and production data, shall be furnished to the inspectors at no charge to the Procuring agency

- 7.3 Should any inspected or tested Goods fail to conform to the Specifications, the Procuring agency may reject the Goods, and the Supplier shall either replace the rejected Goods or make alterations necessary to meet specification requirements free of cost to the Procuring agency.
- 7.4 The Procuring agency's right to inspect, test and, where necessary, reject the Goods after the Goods' arrival in the Procuring agency's country shall in no way be limited or waived by reason of the Goods having previously been inspected, tested, and passed by the Procuring agency or its representative prior to the Goods' shipment from the country of origin.
- 7.5 Nothing in GCC Clause 7 shall in any way release the Supplier from any warranty or other obligations under this Contract.

8. DELIVERY AND DOCUMENTS

- 8.1 The Bidder shall in accordance with the terms specified in the Schedule of Requirements make delivery of the goods. Details of documents to be furnished by the Bidder are specified in SCC.

9. INSURANCE

- 9.1 The goods supplied under the Contract shall be delivered to the Procuring Agency after the payment of all taxes and customs duty, cess, octroi charges etc. Risk will be transferred to the Procuring Agency only after the delivery of these goods has been made to the Procuring Agency. Hence, payment of insurance premium, if any, shall be the responsibility of the Bidder.

10. TRANSPORTATION

- 10.1 The Bidder shall arrange such transportation of the goods as is required to prevent them from damage or deterioration during transit to their final destination as indicated in the Schedule of Requirements.
- 10.2 The goods shall be supplied at the consignee's end (Dow University of Health Sciences, DHA Campus, Karachi) as per Schedule of Requirements on the risk and cost of the Bidder. Transportation including loading/unloading of goods shall be the responsibility of Bidder.

11. INCIDENTAL SERVICES

- 11.1 The Bidder will be required to provide to the Procuring Agency incidental services the cost of which should be included in the total bid price.

12. WARRANTY / GUARANTEE

- 12.1 The term period of warranty / guarantee means the period of twelve **(12) months or in accordance with extended warranty period** from the date on which the Stores have been put into operation and demonstrated to the

University staff. In any case this period shall not exceed six months beyond the warranty expiration period from the date of taking-over of goods.

- 12.2 During the period of warranty / guarantee, the Contractor shall remedy, at his /her expense, all defects in design, materials, and workmanship that may develop or are revealed under normal use of the goods upon receiving written notice from the University; the notice shall indicate in what respect the goods are faulty.
- 12.3 The provisions of this Clause include all the expenses that the Contractor may have to incur for delivery and installation / fixation of such replacement parts, material and equipment as are needed for satisfactory operation of the goods at the Procuring agency's premises.
- 12.4 The Procuring Agency shall promptly notify the Bidder in writing of any claims arising out of this warranty.

13. PAYMENT

- 13.1 The method and conditions of payment to be made to the Bidder under this Contract are specified in SCC.

14. ASSIGNMENT

- 14.1 The Bidder shall not assign, in whole or in part, its obligations to perform to another party under this Contract, except with the Procuring Agency's prior written consent.

15. DELAYS IN THE BIDDER'S PERFORMANCE

- 15.1 Delivery of the goods shall be made by the Bidder in accordance with the time schedule prescribed by the Procuring Agency in the Schedule of Requirements / Contract Agreement.
- 15.2 If at any time in the course of performance of the Contract, the Bidder encounters anything impeding timely delivery of the goods, he shall promptly notify the Procuring Agency in writing of the causes of delay and its likely duration. As soon as practicable, after receipt of the Bidder's notice, the Procuring Agency shall evaluate the situation and may, depending on merits of the situation, extend the Bidder's time for performance, with or without liquidated damages, in which case the extension shall be ratified by the Parties by a supplementary Contract to be treated as an addendum to the original contract.
- 15.3 Any undue delay by the Bidder in the performance of its delivery obligations shall render it liable to the imposition of liquidated damages.

16. PENALTIES LIQUIDATED DAMAGES

16.1 Subject to GCC Clause 18, if the Supplier fails to deliver any or all of the Goods or to perform the Services within the period(s) specified in the Contract, the Procuring agency shall, without prejudice to its other remedies under the Contract, deduct from the Contract Price, as liquidated damages, a sum equivalent to the percentage specified in SCC of the delivered price of the delayed Goods or unperformed Services for each week or part thereof of delay until actual delivery or performance, up to a maximum deduction of the percentage specified in SCC. Once the maximum is reached, the Procuring agency may consider termination of the Contract pursuant to GCC Clause 17.

17. TERMINATION FOR DEFAULT

17.1 The Procuring agency, without prejudice to any other remedy for breach of Contract, by written notice of default sent to the Supplier, may terminate this Contract in whole or in part:

- (a) if the Supplier fails to deliver any or all of the Goods within the period(s) specified in the Contract, or within any extension thereof granted by the Procuring agency pursuant to GCC Clause 15; or
- (b) if the Supplier fails to perform any other obligation(s) under the Contract.
- (c) if the Supplier, in the judgment of the Procuring agency has engaged in corrupt or fraudulent practices in competing for or in executing the Contract.

For the purpose of this clause:

“Corrupt practice” means the offering, giving, receiving or soliciting of anything of value to influence the action of a public official in the procurement process or in contract execution.

“fraudulent practice” means a misrepresentation of facts in order to influence a procurement process or the execution of a contract to the detriment of the Borrower, and includes collusive practice among Bidders (prior to or after bid submission) designed to establish bid prices at artificial non-competitive levels and to deprive the Borrower of the benefits of free and open competition.

17.2 In the event the Procuring agency terminates the Contract in whole or in part, pursuant to GCC Clause 17.1, the Procuring agency may procure, upon such terms and in such manner as it deems appropriate, Goods or Services similar to those undelivered, and the Supplier shall be liable to the Procuring agency for any excess costs for such similar Goods or Services. However, the Supplier shall continue performance of the Contract to the extent not terminated.

18. FORCE MAJEURE

- 18.1 Notwithstanding the provisions of GCC Clauses 15, 16, and 17, the Supplier shall not be liable for forfeiture of its performance security, liquidated damages, or termination for default if and to the extent that its delay in performance or other failure to perform its obligations under the Contract is the result of an event of Force Majeure.
- 18.2 For purposes of this clause, "Force Majeure" means an event beyond the control of the Supplier and not involving the Supplier's fault or negligence and not foreseeable. Such events may include, but are not restricted to, acts of the Procuring agency in its sovereign capacity, wars or revolutions, fires, floods, epidemics, quarantine restrictions, and freight embargoes.
- 18.3 If a Force Majeure situation arises, the Supplier shall promptly notify the Procuring agency in writing of such condition and the cause thereof. Unless otherwise directed by the Procuring agency in writing, the Supplier shall continue to perform its obligations under the Contract as far as is reasonably practical, and shall seek all reasonable alternative means for performance not prevented by the Force Majeure event.

19. TERMINATION FOR INSOLVENCY

- 19.1 The Procuring agency may at any time terminate the Contract by giving written notice to the Supplier if the Supplier becomes bankrupt or otherwise insolvent. In this event, termination will be without compensation to the Supplier, provided that such termination will not prejudice or affect any right of action or remedy which has accrued or will accrue thereafter to the Procuring agency.

20. TERMINATION FOR CONVENIENCE

- 20.1 The Procuring agency, by written notice sent to the Supplier, may terminate the Contract, in whole or in part, at any time for its convenience. The notice of termination shall specify that termination is for the Procuring agency's convenience, the extent to which performance of the Supplier under the Contract is terminated, and the date upon which such termination becomes effective.
- 20.2 The Goods that are complete and ready for shipment within thirty (30) days after the Supplier's receipt of notice of termination shall be accepted by the Procuring agency at the Contract terms and prices. For the remaining Goods, the Procuring agency may elect:
- (a) to have any portion completed and delivered at the Contract terms and prices; and/or
 - (b) to cancel the remainder and pay to the Supplier an agreed amount for partially completed Goods and Services and for materials and parts previously procured by the Supplier.

21. RESOLUTION OF DISPUTES

- 21.1 The Procuring agency and the Supplier shall make every effort to resolve amicably by direct informal negotiation any disagreement or dispute arising between them under or in connection with the Contract.
- 21.2 If, after thirty (30) days from the commencement of such informal negotiations, the Procuring agency and the Supplier have been unable to resolve amicably a Contract dispute, either party may require that the dispute be referred for resolution to the formal mechanisms specified in SCC. These mechanisms may include, but are not restricted to, conciliation mediated by a third party, adjudication in an agreed manner and/or arbitration.

22. GOVERNING LANGUAGE

- 22.1 The Contract shall be written in the language specified in SCC. Subject to GCC Clause 23, the version of the Contract written in the specified language shall govern its interpretation. All correspondence and other documents pertaining to the Contract which are exchanged by the parties shall be written in the same language.

23. APPLICABLE LAW

- 23.1 The Contract shall be interpreted in accordance with the laws of the Procuring agency's country (Islamic Republic of Pakistan), unless otherwise specified in SCC.

24. NOTICES

- 24.1 Any notice given by one party to the other pursuant to this Contract shall be sent to the other party in writing or by cable, telex, or facsimile and confirmed in writing to the other party's address specified in SCC.
- 24.2 A notice shall be effective when delivered or on the notice's effective date, whichever is later.

25. TAXES AND DUTIES

- 25.1 Supplier shall be entirely responsible for all taxes, duties, license fees, etc., incurred until delivery of the contracted Goods to the Procuring agency in case of Delivered Duty Paid (DDP) basis.

C: INVITATION FOR BIDS (IFB) / NOTICE INVITING TENDER (NIT)

		<h1 style="text-align: center;">DOW UNIVERSITY OF HEALTH SCIENCES</h1>	
No. DUHS/P&D/2022/11175		Dated: October 13, 2022	
<h2 style="background-color: black; color: white; padding: 5px;">NOTICE INVITING TENDER</h2>			
<p>Sealed tenders from interested Dealers / Distribution / Manufacturers having registration with Federal Board of Revenue (FBR), Income Tax Department, Sindh Revenue Service Board, Sales Tax and Pakistan Engineering Council (PEC) in appropriate category and License of Electric Inspectorates Sindh.</p>			
S. No.	NAME OF WORK	METHOD OF PROCUREMENT	
1.	SUPPLY, FIXING, INSTALLATION & COMMISSIONING OF 40.8KW GRID TIED SOLAR SYSTEM AT DOW INTERNATIONAL DENTAL COLLEGE (DHA CAMPUS) KARACHI.	Single Stage - Two Envelope Procedure as per rule 46 sub rule 2 of SPP Rules 2010 (Amended upto date)	
Tender Fee	Rs. 2,000/- (Rupees Two Thousand Only) Non-Refundable in shape of Pay Order / Demand Draft in favor of Dow University of Health Sciences, Karachi.		
Bid Security	2% of the total bid value.		
Purchasing Date & Time	From the date of publishing to 01-11-2022 (10 a.m to 03 p.m)		
Bids Delivery & Opening Date & Time	02-11-2022 at 11:00 a.m & 11:30 a.m.		
<p>Detailed Specification are mentioned in the prescribed tender documents alongwith terms and conditions. Bidding documents can be download from SPPRA website or Dow University of Health Sciences, website. Conditional Bids, Telegraphic Bids, Bids not accompanied by Bid Security of required amount and form, bids received after specific date and time and bids of Black Listed firms will be rejected.</p> <p>In case of any unforeseen situation or government holiday resulting in closure of office on the date of opening, bids shall be submitted / opened on next working day at the given time. The Dow University of Health Sciences, Karachi (DUHS) reserves the right to reject any or all the bids subject to the relevant provisions of SPP Rules 2010 (Amended upto date).</p>			
<p>ADDRESS FOR PURCHASING OF BIDDING DOCUMENTS, SUBMISSION AND OPENING OF BIDS: Office of the Director Planning & Development, Dow University of Health Sciences (DMC Campus), 5th Floor Administration Block, Baba-e-Urdu Road near Civil Hospital Karachi.</p>			
<p>DIRECTOR Planning & Development Dow University of Health Sciences, Karachi</p>		<p>www.duhs.edu.pk Baba-e-Urdu Road, Karachi - 74200 Pakistan. Tel: 021-99216065 Fax: 021-99216065</p>	

D: BID DATA SHEET

The following specific data for the goods to be procured shall complement, supplement, or amend the provisions in the Instructions to Bidders (ITB). Whenever there is a conflict, the provisions herein shall prevail over those in ITB.

INTRODUCTION

- ITB 1.1 Name of Procuring Agency:**
Dow University of Health Sciences, Karachi.
- ITB 1.1 Project/Scheme Allocation Number:** UDP
Project / Scheme Allocation Amount: PKR. 5.000 Million
- ITB 1.1 Name of Project/Scheme:**
Supply, Fixing, Installation & Commissioning of 40.8kw Grid Tied Solar System at Dow International Dental College (DHA campus) Karachi.
- ITB 1.1 Name of Contract:**
Supply, Fixing, Installation & Commissioning of 40.8kw Grid Tied Solar System at Dow International Dental College (DHA campus) Karachi.
(Tender Ref. No. DUHS/P&D/2022/11175, Dated: 13-10-2022)

THE BIDDING PROCEDURE

- ITB 4** Bids shall be accepted under the **Single Stage - Two Envelope Procedure**.

PREPARATION OF BIDS

- ITB 7.1** Language of the bid shall be English
- ITB 9.6** The price quoted shall be on **delivered duty paid (DDP) Basis** at Consignee's End (DHA Campus of Dow University of Health Sciences, Karachi).
- ITB 10.1** The price quoted shall be in **Pak Rupees**.
- ITB 13.1** The bidder shall furnish a bid security / earnest money equivalent to **TWO PERCENT (2%) of the total bid price of bidder** in the form of a Call Deposit, Bank Draft or a Bank Guarantee issued by a scheduled bank of Pakistan, in favour of the Dow University of Health Sciences, Karachi. The bid security should be valid 28 days beyond the bid validity period.
- ITB 14.1** Bid validity period shall be **90 days**.
- ITB 15.1** Alternate Bids shall not be allowed.

SUBMISSION OF BIDS

ITB 16.1 (b) The identification of this bidding process is:

Supply, Fixing, Installation & Commissioning of 40.8kw Grid Tied Solar System at Dow International Dental College (DHA campus) Karachi.

N.I.T No. DUHS/P&D/2022/11175, Dated: 13-10-2022

ITB 16.1 (c) Dow University of Health Sciences, Baba-e-Urdu Road, Besides Civil Hospital, Karachi.

“Must bear the name of the bidder” and a warning “Do Not Opened Before the time and date of bid opening”.

ITB 17.1 Deadline for bid submission: **02-11-2022 upto 11:00 Hrs.**

OPENING & EVALUATION OF BIDS

ITB 20.1 The bid opening shall take place at:

Dow University of Health Sciences, Baba-e-Urdu Road, Besides Civil Hospital, Karachi.

Date: 02-11-2022

Time: 11:30 Hrs.

CONTRACT AWARD

ITB 30.1 Qty. could be increased or decreased during the contract period (including extended period) according to the actual requirement besides excluding / dropping any item from the tendering process.

ITB 34.1 The successful Bidder shall furnish the Performance Security equivalent to **TEN PERCENT (10%) of the total Contract amount** in the form of Call Deposit, Bank Draft or a Bank Guarantee issued by a scheduled bank of Pakistan, in favour of the Dow University of Health Sciences, Karachi.

E: SPECIAL CONDITIONS OF CONTRACT (SCC)

1. DEFINITIONS (GCC CLAUSE 1)

GCC 1.1 (g) The Procuring Agency is the Dow University of Health Sciences, Karachi.

GCC 1.1 (h) The Bidder is: _____
(name and address of the successful bidder)

2. BID SECURITY (ITB CLAUSE 13)

ITB 13.1 The Bidder shall furnish, as part of its financial proposal/bid, refundable Bid Security in Pak Rupees @ 2% of the total bid value in the shape of Call Deposit, Bank Draft or a Bank Guarantee in the name of the Dow University of Health Sciences, Karachi. The financial bid found deficient of the Bid Security will be rejected. No personal cheque in lieu thereof will be acceptable at any cost. The previous Bid Security, if any, will not be considered or carried forward. However, the Bid Security of the successful Bidder will be returned upon submission of Performance Security equal to 10% of the Contract amount that will remain with the Dow University of Health Sciences, Karachi till satisfactory completion of the Contract period. After delivery and acceptance of the Goods, the performance security shall be reduced to five (5) percent of the Contract Price to cover the Supplier's warranty obligations.

3. TECHNICAL SPECIFICATIONS / STANDARDS (GCC CLAUSE 3)

GCC 3.1 The technical specifications of the goods provided in these bidding document are only for widest possible competition and not for favor any single contractor or supplier nor put others at a disadvantage. However, the brand name, catalogue No. / Name etc., if any, has only been used for the reference purpose. Goods offered **“ATLEAST EQUIVALENT OR HAVING BETTER TECHNICAL SPECIFICATIONS”** shall also be considered.

4. INSPECTIONS AND TESTS (GCC CLAUSE 7)

GCC 7.1, 7.2, 7.3
7.4 & 7.5 The goods received in the Dow University of Health Services, Karachi from the Bidder will be thoroughly inspected and examine by Engineer to make sure that the goods received conform to the specifications laid down in the bid documents and which have been approved by the Procurement Committee for procurement. The Engineer will submit its inspection report, any deficiency pointed out by the Engineer shall have to be rectified by the Bidder free of cost.

5. DELIVERY AND DOCUMENTS (GCC CLAUSE 8)

GCC Clause 8.1 The Bidder shall provide the following documents at the time of delivery of goods to the Store / Warehouse of the Dow University of Health Sciences, Karachi for verification duly completed in all respects:

- i. Original copies of Delivery Note (Delivery Challan) (in duplicate) showing item's description, make, model, quantity as well as Lot Number, Batch Number, Registration Number, manufacturing and expiry dates (if applicable).
- ii. Original copies of the Bidder's invoices (in duplicate) showing warranty, item's description, make, model as well as Lot Number, Batch Number, Registration Number, manufacturing and expiry dates (if applicable) per unit cost, and total amount.
- iii. Original copies of the Sales Tax Invoices (where applicable) in duplicate showing item's description, quantity, per unit cost (excluding GST), as university is exempted from GST
- iv. Manufacturer's or Bidder's warranty certificate.
- v. Inspection certificate issued by the nominated inspection Engineer along with Bidder's factory inspection report.
- vi. Certificate of origin.

6. INSURANCE (GCC CLAUSE 9)

GCC 9.1 The goods supplied under the Contract shall be on DDP basis at consignee's end under which risk will be transferred to the Procuring Agency only after it has taken delivery of the goods. Hence insurance coverage is Bidder's responsibility.

7. WARRANTY / GUARANTEE (GCC CLAUSE 12)

GCC 12.1 The goods shall be accompanied by manufacturer standard warranty / guarantee or 1 year or extended warranty, whichever is more.

GCC 12.2 The Procuring Agency shall promptly notify the Bidder in writing of any claims arising out of this warranty.

8. PAYMENT (GCC CLAUSE 13)

GCC 13.1 The method and conditions of payment to be made to the Bidder under this Contract shall be as follows:

- (a) Payment shall be made in Pak Rupees.
- (b) Secured advance against the deliveries of Solar Panels, inverters and cables i.e 70% of the Purchase Price (purchase receipt should be produced) shall be paid upon delivery at site, while remaining payment after satisfactory installation, integration and testing of the products at the Project site (s), subject to the production of installation and Operational Acceptance certificates
- (c) The payment will be made to the Bidder within 45 days of the receipt of original delivery challan(s) and invoice(s) in duplicate duly completed in all respect and signed and stamped by the Director of Works & Services. The Inspection Engineer will prepare and submit a report of physical inspection with a certificate to the effect that the goods conform to the specifications laid down in the bidding documents.

9. PENALTIES/ LIQUIDATED DAMAGES (GCC CLAUSE 16)

GCC 16.1 In case deliveries are not completed within the time frame specified in the schedule of requirements / contract, a Show Cause Notice will be served on the Bidder which will be followed by cancellation of the Contract to the extent of non-delivered portion of installments. No supplies will be accepted and the amount of Performance Guarantee / Security to the extent of non-delivered portion of supplies of relevant installments will be forfeited. If the firm fails to supply the whole installments, the entire amount of Performance Guarantee/Security will be forfeited to the Government Account and the firm will be blacklisted at least for two years for future participation in bids:

The liquidated damage shall be 0.5 % per week or part thereof. The maximum amount of liquidated damages shall be 10% of the amount of contract. Once the cumulative amount of liquidated damages reaches ten percent (10%) of the amount of the contract, the Procuring Agency shall rescind the contract, without prejudice to other courses of action and remedies open to it.

10. RESOLUTION OF DISPUTES (GCC CLAUSE 21)

GCC 21.2 In the case of a dispute between the Procuring agency and the Supplier, the dispute shall be referred to the dispute resolution mechanism as defined in rule 31, 32 and 34 of the SPPRA Rules, 2010 (Amended 2019).

11. GOVERNING LANGUAGE (GCC CLAUSE 22)

GCC 22.1 The language of this Contract shall be ENGLISH.

12. APPLICABLE LAWS (GCC CLAUSE 23)

GCC 23.1 The Contract shall be governed by the Laws of Pakistan and the Courts of Karachi - Pakistan shall have exclusive jurisdiction.

13. NOTICES (GCC CLAUSE 24)

Procuring Agency's address for notice purposes:

Director Planning & Development,
Dow University of Health Sciences (DMC Campus) Baba-e-Urdu Road, Beside Civil Hospital,
Karachi.
Phone No. + 92-21-38771000 (Ext.5820)

Bidder's address for notice purposes:

Name of Bidder: _____

Name of Contact Person & Designation: _____

Phone No. _____

Fax No. _____

Mobile Phone No. _____

Email Address _____

F: SCHEDULE OF REQUIREMENTS

The delivery schedule hereafter expressed the date of delivery required.

SR.	DESCRIPTION	QTY	REQUIRED DELIVERY SCHEDULE FROM THE DATE OF CONTRACT AWARD	LOCATION
01.	SUPPLYING, FIXING, INSTALLATION & COMMISSIONING OF 40.8KW GRID TIED SOLAR SYSTEM TO GENERATE GREEN ENERGY. (SPECIFICATIONS OF ABOVE ITEMS ARE ATTACHED) Bidder have to submit the net-metering file for 82.84kW.	01	Delivery & Installation within 45 to 60 Days or earlier.	Dow International Dental College, DHA Campus, Karachi

NOTE: SPECIFICATIONS OF ABOVE ITEMS ARE ATTACHED.

G: TECHNICAL SPECIFICATIONS

(BIDDERS TO ENDORSE REPLY/REMARKS AGAINST EACH CLAUSE AND STAMP, SIGN EACH PAGE)

S. No	DETAILED SPECIFICATIONS AND REQUIREMENTS	<u>BIDDER'S REPLY/ REMARKS</u>
01	<u>SOLAR PANEL</u>	
a.	Solar Module of Tier 1 Chinese Company, American, UK or equivalent. The company should come in Top 10 list of Bloomberg's Rankings 2021.	
b.	Photovoltaic module: 545Wp (144 cells)	
c.	Technology: MBB HC Technology (P type Mono-crystalline)	
d.	Module frame: Non-corrosive anodized aluminum	
e.	Module efficiency: equal to or greater than 21%	
f.	Junction box: IP68 enclosure	
g.	Temp power coefficient: equal or less than -0.35%/°C	
h.	Annual Degradation: equal to or less than 0.55% per year	
i.	Certifications: i. IEC 61215:2016 ii. IEC 61730:2016	
j.	Manufacturer must be certified with: i. ISO 9001:2015 ii. ISO 14001:2015 iii. ISO 45001:2018	
k.	PID resistance test passed	
l.	Product material & workmanship warranty: 12 years (minimum) Product Linear power output warranty: 25 years	
2.	<u>SOLAR INVERTER</u>	
a.	Solar Inverter should be in USA, Europe, TOP 6 rating either Chinese, or equivalent	
b.	Rated Capacity of three phase solar On-grid Inverters 27kW	
c.	Operating temperature range: -25~60°C (>50°C derating)	
d.	Inverter enclosure class: IP65	
e.	Efficiency of inverter: >98%	
f.	Night time consumption <2W	
g.	Inverter must have following certifications: i. IEC 62109-1/-2 ii. IEC 62116 iii. IEC 60068 iv. IEC 61727 v. G59/3	
h.	Inverter Must have following protections:	

	<ul style="list-style-type: none"> i. Input-side Disconnection Device ii. Anti-islanding Protection iii. AC Overcurrent Protection iv. DC Reverse-polarity Protection v. DC Insulation Resistance Detection 	
i.	Inverter must be equipped with 4G or WAN option for remote monitoring the PV plant from any PC or smart phone around the world.	
j.	Warranty of inverter: 5 years	
3.	<u>SPV PANEL STRUCTURE: (As per Drawing)</u>	
a.	Mounting must be of Anodized Aluminum.	
b.	Module & structure should be fixed with SS 304 grade fastening bolts.	
c.	Mounting should withstand the wind gust of 100km/h. Provide its analysis report	
d.	Design life of mountings: 25 years	
e.	Warranty of mountings: 10 years against corrosion and other seasonal effects	
4.	<u>CABLES AND DUCTS</u>	
a.	DC cables: Flexible (voltage range 1000V) and voltage Losses <1%	
b.	AC cables: Pakistan cables/crescent/fast cable made & Voltage losses < 2%	
5.	<u>DC FUSES, BREAKERS AND AC BREAKERS</u>	
	All AC breaker and DC fuses should be Schneider, ABB, little fuse or Terasaki made.	
6.	<u>EARTHING</u>	
a.	PV Structure, PV modules & inverters should be properly ground.	
7.	<u>SEALING WORKS</u>	
	Self-drilling screws should be with rubber washer and foots should be fixed using EPDM sheet to prevent water leakage.	

NOTE:

- i. Bidder will submit the sample / partial sample, according to the nature of the ordered for the approval, prior to supply of the entire quantities.*

2. MANUFACTURER'S AUTHORIZATION FORM
[SEE CLAUSE 11.1 (a) OF THE INSTRUCTION TO BIDDERS]

Dated: _____

To: The Dow University of Health Sciences Karachi.

WHEREAS **[name of the Manufacturer]** who are established and reputable Manufacturers of **[name and /or description of the goods]** having factories at **[address of factory]** do hereby authorize **[name and address of Bidder / Agent]** to submit a bid, and subsequently follow- up / negotiate and sign the Contract with you against Invitation for Bids (IFB) / Tender Notice for the goods manufactured, by us, under the patent name of _____
_____ for performance of the contract.

We hereby commit and assure our full guarantee and warranty / guarantee as per Clause 12 of the General Conditions of Contract for the goods offered for supply by the above mentioned firm against this Invitation for Bids.

[Signature for and on behalf of Manufacturer]
[Name and Designation]

Note:
This letter of authority should be on the letterhead of the Manufacturer and should be signed by a person competent and having the power of attorney to bind the Manufacturer. It should be included by the Bidder in its bid.

3. CONTRACT FORM

THIS AGREEMENT made the _____ day of __2022 between *Dow University of Health Sciences, Karachi of Islamic Republic of Pakistan* (hereinafter called “the Procuring Agency”) of the one part and *[Name of Bidder]* of _____
[city and country of Bidder] (hereinafter called “the Bidder”) of the otherpart:

WHEREAS the Procuring Agency invited bids for certain goods and ancillary services, viz., *[brief description of goods and services]* and has accepted a bid by the Bidder for the supply of those goods and services in the sum of _____
[contract price in words and figures] (hereinafter called “the Contract Price”).

NOW THIS AGREEMENT WITNESSETH AS FOLLOWS:

1. In this Agreement words and expressions shall have the same meanings as are respectively assigned to them in the Conditions of Contract referred to.
2. The following documents shall be deemed to form and be read and construed as part of this Agreement, viz.:
 - (a) the Bid Form and the Price Schedule submitted by the Bidder;
 - (b) the Schedule of Requirements;
 - (c) the Technical Specifications;
 - (d) the General Conditions of Contract;
 - (e) the Special Conditions of Contract; and
 - (f) the Procuring Agency’s Notification of Award.

2. In consideration of the payments to be made by the Procuring Agency to the Bidder as hereinafter mentioned, the Bidder hereby covenants with the Procuring Agency to provide the goods and services and to remedy defects therein in conformity in all respects with the provisions of the Contract

4. The Procuring Agency hereby covenants to pay the Bidder in consideration of the provision of the goods and services and the remedying of defects therein, the Contract Price or such other sum as may become payable under the provisions of the contract at the times and in the manner prescribed by the contract.

IN WITNESS whereof the parties hereto have caused this Agreement to be executed in accordance with their respective laws the day and year first above written.

Signed / Sealed by the Manufacturer /
Authorized Bidder / Authorized Agent

Signed / Sealed by Procuring Agency

4. INTEGRITY PACT (AFFIDAVIT)

DECLARATION OF FEES, COMMISSION AND BROKERAGE ETC. PAYABLE BY THE SUPPLIERS OF GOODS, SERVICES & WORKS IN CONTRACTS WORTH RS. 10.00 MILLION OR MORE

M/s. _____, the service provider hereby declared that:

- (a) Its intention not to obtain the procurement / services / work of any contract, right, interest, privilege, or other obligation or benefit from the DUHS or any administrative or financial offices thereof or any other department under the control of the DUHS through any corrupt practice(s).
- (b) Without limiting the generality of the forgoing the bidder / company / firm / agency represents and warrants that it has fully declared the charges, fees, commission, taxes, levies etc, paid or payable to anyone and not given or agreed to give and shall not give or agree to give to anyone within the DUHS directly or indirectly through any means any commission, gratification, bribe, gifts, kickback whether described as consultation fee or otherwise, with the object of obtaining or including the procurement or service contract or order or other obligations whatsoever from the DUHS, except that which has been expressly declared pursuant hereto.
- (c) The bidder / company / firm / agency / accepts full responsibility and strict liability for making any false declaration / statement, not making full disclosure, misrepresenting facts or taking any action likely to degrade the purpose of declaration, representation and warranty. It agrees that any contract / order obtained aforesaid shall without prejudice to any other right & remedies available to the DUHS under any law, contract, or other instrument, be stand void at the discretion of the DUHS.
- (d) Notwithstanding any right and remedies exercised by the DUHS in this regard, bidder / company / firm / agency agrees to indemnify the DUHS for any loss or damage incurred by it on account of its corrupt business practice & further pay compensation to the DUHS in any amount equivalent to the loss of any commission, gratification, bribe, gifts, kickback given by the bidder / company / firm / supplier / agency / service provider as aforesaid for the purpose of obtaining or inducing procurement / work / service or other obligation or benefit in whatsoever from the DUHS.

Dow University of Health Sciences
Signature & Seal

(Name of Security Firm)
Signature & Seal

Note: This integrity pact is mandatory requirement other than auxiliary services / works.

2. PRICE SCHEDULE IN PAK RUPEES DELIVERED DUTY PAID (DDP BASIS)

FOR GOODS OFFERED WITHIN THE PROCURING AGENCY'S COUNTRY

PRICE SCHEDULE - SUPPLIES

Name of Bidder :

IFB Number : DUHS/P&D/2022/11175, Dated: 13-10-2022

Components	Make	Model	Spec	Qty	Unit Price	Total
Solar panel			545W	75 Nos.		
Inverter			27kW, 3P	2 No.		
Grand Total without GST						

Components	Make	Model	Spec	Qty	Unit Price	Total
Cables						
D/C cable Flexible	1000V DC Cable		4mm ² single core, red	200mtr		
D/C cable Flexible	1000V DC Cable		4mm ² single core, black	200mtr		
A/C cable	Pakistan Cable		10mm ² , 4 core	40mtr		
Earthing cable	Pakistan Cable		4mm ²	50mtr		
			10mm ²	50mtr		
Breakers						
DC fuse for strings	ABB/Little Fuse/Schneider		15A, 1000V	8Nos.		
AC Breaker	Terasaki/ABB/Himel		63A, 4Pole	2Nos.		
Magnetic Contactor	Terasaki/ABB/Himel		63A, 3Pole	2Nos.		
Surge Suppressor	Schneider/Himel/ABB		40kA	2Nos.		
Mechanical						
Panel Mounting (As per provided drawing)	Anodized Aluminum Mounting		Panel fixing Rails	202 ft.		
			Rail L Foots for fixing	202 Nos.		
			Mid Clamp	174 Nos.		
			Side Clamp	28 Nos.		
			SS nut bolts	1 lot.		
Self-drilling SS screws (6x75mm) with EPDM sheet				202 Nos.		
Piping and Accessories						
PVC pipe for DC Cables with complete fixing accessories	Pak Arab/Eqv		1.25"	30 Nos.		

PVC pipe for AC Cables with complete fixing accessories	Pak Arab/Eqv	1.5"	15 Nos.		
Complete Installation accessories			1 lot		
Grand Total including Withholding tax					

SIGNATURE OF BIDDER

Note:

- (i) In case of discrepancy between unit price in figure and words and total price mentioned in words shall prevail.
- (ii) DG set price should be in CNF / CFR, local items will be quoted in PKR (DDP).

PRICE SCHEDULE - SERVICES

Name of Bidder :

IFB Number : DUHS/P&D/2022/11175, Dated: 13-10-2022

Services	Total
Transportation	
Installation, testing, and commissioning Charges for 40.8kW Solar System including solar panels, inverters, panel mountings, cables, AC breakers, DC fuses and all accessories	
Grand Total including WHT & SST	

SIGNATURE OF BIDDER

Note:

- (i) In case of discrepancy between unit price in figure and words and total price mentioned in words shall prevail.
- (ii) DG set price should be in CNF / CFR, local items will be quoted in PKR (DDP).

Name _____

In the capacity of _____

Signed _____

Duly authorized to sign the Bid for and on behalf of _____

Date _____

EXPERIENCE OF SIMILAR SUPPLY AND INSTALLATION
DURING LAST 3 YEARS

Sr. No	Assignment Description	Name / Contact Details of Client	Cost	Start Date	End Date	Remarks
1.						
2.						
3.						
4.						
5.						
6.						
7.						
8.						
9.						
10.						

Name _____

In the capacity of _____

Signed _____

Duly authorized to sign the Bid for and on behalf of _____

Date _____

J) DRAWINGS:

Side Clamp

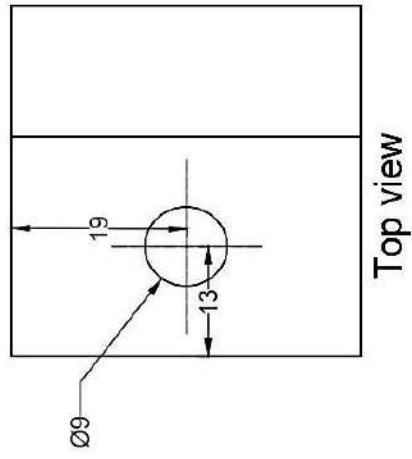
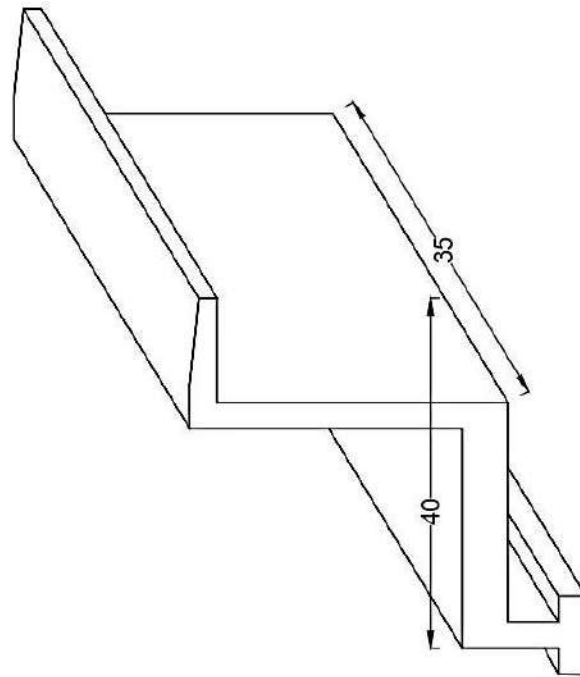

Slider

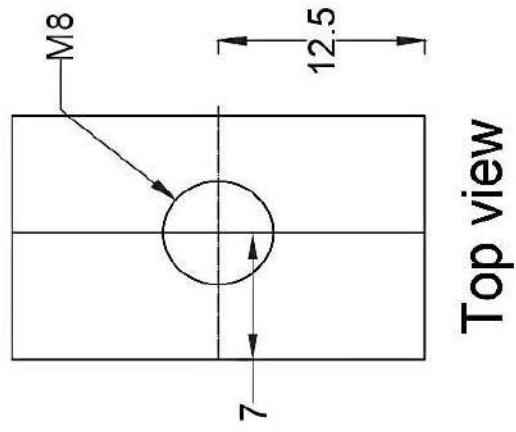
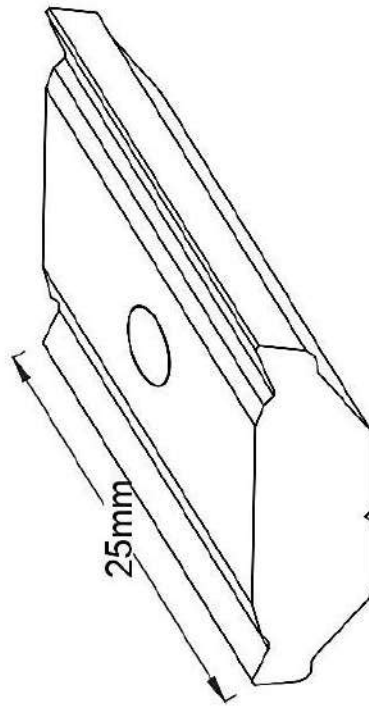

Top view

Rail L Foot

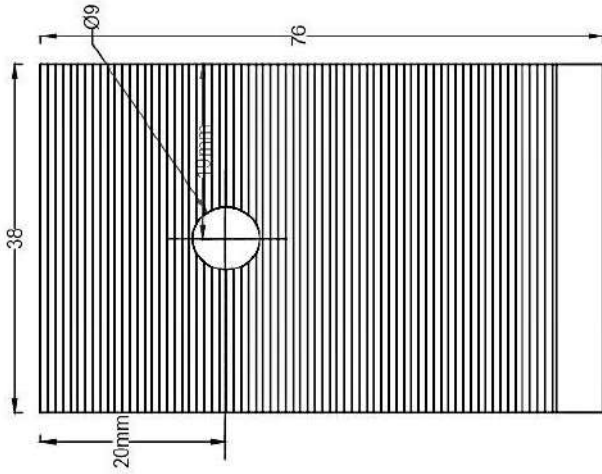
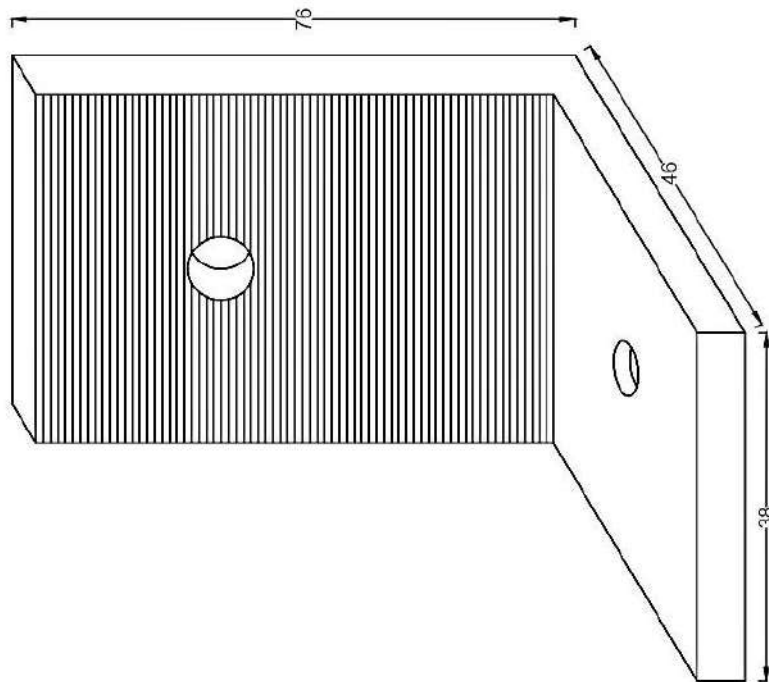

Side view

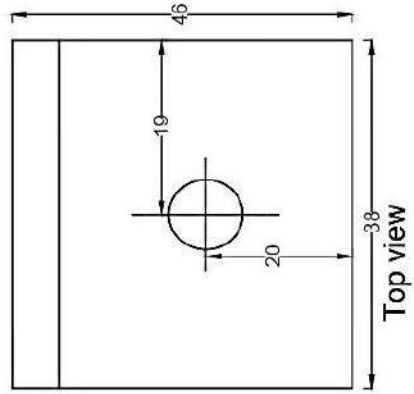

Top view

Panel Placement Drawing

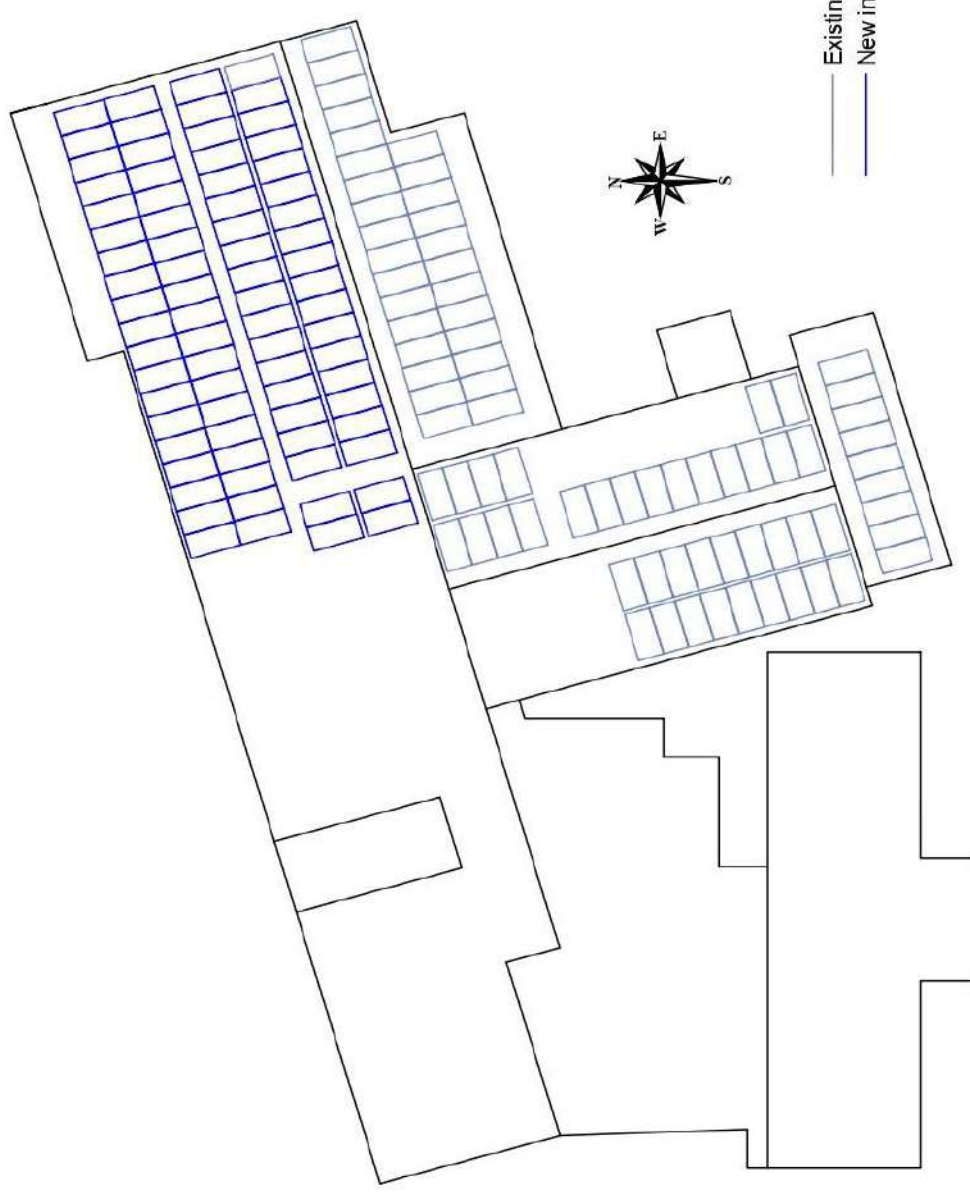

Client: <i>low university of health & sciences</i>		Project Developer		Drawing Date:		Designed By:		Copies to Project Coordinator:		Panels:		All dimensions are in mm	
Project Name: <i>Smart Grid Test System</i>		Name:		17th June 2021		Name:		Name:		75lot. x 543Wp		Quantity: <i>8000</i>	
Site: <i>University Building, OTH Campus Du-S, SUPARCO Road, Islamabad</i>		Drawing No.:		DW/DM/45/01		Copy to Project Manager:		Copy to Project Engineer:		Panels:		Quantity: <i>8000</i>	
		Name:				Name:		Name:		2No. x 27AWp		Date: <i>6th July 2022</i>	

Mid Clamp

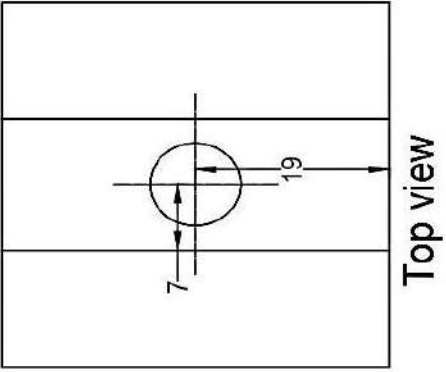
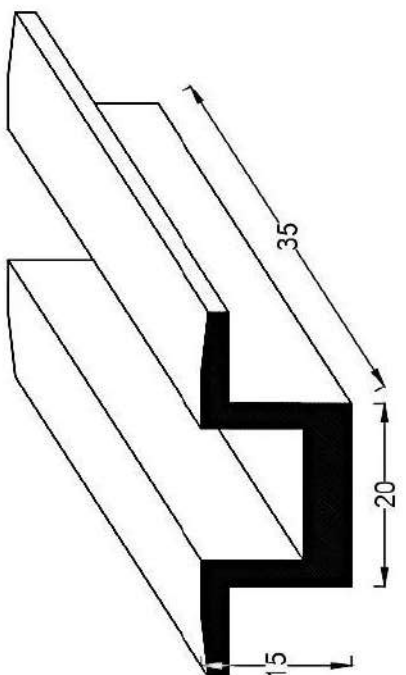

Panel Rail

