

DOW UNIVERSITY OF HEALTH SCIENCES, KARACHI



BIDDING DOCUMENTS

Single Stage – Single Envelope Procedure
As per Rule 46 (1) of SPPR, 2010 (Amended upto date)

IFB / NIT No. DUHS/P&D/2022/11300, Dated: 26 December, 2022

**“ESTABLISHMENT OF PLASMA COLLECTION &
PROCESSING FACILITY FOR BBMF DIABAR AT
OJHA CAMPUS, DUHS, KARACHI.”**
(REF NO: DUHS/W&S-NIT/104)

**OFFICE OF THE DIRECTOR PLANNING & DEVELOPMENT
DOW UNIVERSITY OF HEALTH SCIENCES,
BABA-E-URDU ROAD, BESIDES CIVIL HOSPITAL, KARACHI**

TABLE OF CONTENTS

Description	Page No.
INVITATION FOR BIDS	4
Form Notice Inviting Tender	4
INSTRUCTIONS TO BIDDERS	5
A. General	
IB.1 Scope of Bid	6
IB.2 Source of Funds	6
IB.3 Eligible Bidders	6
IB.4 One Bid Per Bidder	6
IB.5 Cost of Bidding	6
B. Bidding Documents	
IB.7 Contents of Bidding Documents	7
IB.8 Clarification of Bidding Documents	7
IB.9 Amendment of Bidding Documents	7
C. Preparation of Bids	
IB.10. Language of Bid	8
IB.11 Documents Accompanying the Bid	8
IB.12 Bid Prices	9
IB.13 Currencies of Bid and Payment	10
IB.14 Bid Validity	10
IB.15 Bid Security	10
IB.16 Alternate Proposals by Bidder	11
IB.17 Pre-Bid Meeting	11
IB.18 Format and Signing of Bid	11
D. Submission of Bids	
IB.19 Sealing and Marking of Bids	12
IB.20 Deadline for Submission of Bids	13
IB.21 Late Bids	13
IB.22 Modification, Substitution and Withdrawal of Bids	14
E. Bid Opening and Evaluation	
IB.23 Bid Opening	14
IB.24 Process to be Confidential	14
IB.25 Clarification of Bids	15
IB.26 Examination of Bids and Determination of Responsiveness	15
IB.27 Correction of Errors	15
IB.28 Evaluation and Comparison of Bids	16

F.	Award of Contract	
	IB.29 Award	16
	IB.30 Employer’s Right to Accept any Bid and to Reject any or all Bids	17
	IB.31 Notification of Award	17
	IB.32 Performance Security	17
	IB.33 Signing of Contract Agreement	18
	IB.34 General Performance of the Bidders	18
	IB.35 Integrity Pact	18
	IB.36 Instructions Not Part of Contract	18
	BIDDING DATA	19
	NOTES ON BIDDING DATA	20
	BIDDING DATA	21-22
	CONTRACT / BIDDING DATA	23
	FORM OF BID AND APPENDICES TO BID	24
	FORM OF BID	25-26
	Appendix-A to Bid : Bidding Data	27
	Appendix-B to Bid : Bill of Quantities	28-33
	Appendix-C to Bid : Proposed Construction Schedule	34
	Appendix-D to Bid : Method of Performing the Work	35
	Appendix-E to Bid : List of Major Equipment – Related Items	36-37
	Appendix-F to Bid : Construction Camp and Housing Facilities	38
	Appendix-G to Bid : Organization Chart of the Supervisory Staff and Labor	39
	Appendix-H to Bid : Integrity Pact	40
	FORMS	41
	BID SECURITY	42-43
	PERFORMANCE SECURITY	44-45
	CONTRACT AGREEMENT	46-47
	BILL OF QUANTITIES	48
	BID SECURITY	49-72
	DRAWINGS	73-100

INVITATION FOR BIDS



OFFICE OF THE DIRECTOR PLANNING & DEVELOPMENT DOW UNIVERSITY OF HEALTH SCIENCES

Baba-e-Urdu Road, Karachi-74200 Pakistan. Direct No. 92-21-9216065 Fax:99216065
Tel: 9215754-57 Ext:5811 Website: www.duhs.edu.pk

No. DUHS/P&D/2022/11300

Dated: December 26, 2022

TENDER NOTICE

Dow University of Health Sciences (DUHS), Karachi is a Public Sector University invites the sealed bids for following Services from well-reputed Companies / Bidders available on 'List of Active Tax Payers' of FBR websites (for Income Tax) & SRB (For Sales Tax) and Pakistan Engineering Council (PEC) in appropriate category and specified codes for following work.

S. No:	NAME OF WORK	METHOD OF PROCUREMENT
1.	ESTABLISHMENT OF PLASMA COLLECTION & PROCESSING FACILITY FOR BBMF DIABAR AT OJHA CAMPUS, DUHS, KARACHI. (Ref No: DUHS/W&S-NIT/104)	Single Stage – Single Envelope Procedure as per rule 46 sub rule-2 of SPP Rules 2010 (Amended upto date)
2.	SUPPLY / FIXING / INSTALLATION / TESTING & COMMISSIONING OF HVAC SYSTEM AT PLASMA COLLECTION & PROCESSING FACILITY FOR BBMF DIABAR AT OJHA CAMPUS, DUHS, KARACHI (Ref No: DUHS/W&S-NIT/105)	Single Stage – Two Envelope Procedure as per rule 46 sub rule-2 of SPP Rules 2010 (Amended upto date)
3.	(RE-RE-TENDER) HIRING OF JANITORIAL SERVICES FOR HEALTH FACILITIES OF DUHS ALONG WITH DOW LAB. COLLECTIONS POINTS IN KARACHI CITY AND ACROSS SINDH PROVINCE BESIDES QUETTA & HUB CITY OF BALUCHISTAN PROVINCE (Ref No: DUHS/W&S-NIT/106)	Single Stage – Two Envelope Procedure as per rule 46 sub rule-2 of SPP Rules 2010 (Amended upto date)
4.	(RE-RE-TENDER) REPAIR & MAINTENANCE SERVICES FOR PASSENGER LIFTS AND PATIENT / BED LIFTS. (Ref No: DUHS/W&S-NIT/107)	Single Stage – Single Envelope Procedure as per rule 46 sub rule-1 of SPP Rules 2010 (Amended upto date)

Tender Fee	Rs. 2,000/- (Rupees Two Thousand Only) Non-Refundable in shape of Pay Order / Demand Draft in favor of Dow University of Health Sciences, Karachi.
Bid Security	Bid Security amount shall be compliance as mentioned in bidding documents
Purchasing Date & Time	From the date of publishing to 16-01-2023 (10 a.m to 02 p.m)
Bids Delivery & Opening Date & Time	17-01-2023 at 11:00 a.m & 11:30 a.m.

Detailed Specification are mentioned in the prescribed tender documents along with terms and conditions. Bidding documents can be download from SPPRA website or Dow University of Health Sciences, website. Conditional Bids, Telegraphic Bids, Bids not accompanied by Bid Security of required amount and form, bids received after specific date and time and bids of Black Listed firms will be rejected.

In case of any unforeseen situation or government holiday resulting in closure of office on the date of opening, bids shall be submitted / opened on next working day at the given time. The Dow University of Health Sciences, Karachi (DUHS) reserves the right to reject any or all the bids subject to the relevant provisions of SPP Rules 2010 (Amended upto date).

ADDRESS FOR PURCHASING OF BIDDING DOCUMENTS, SUBMISSION AND OPENING OF BIDS:

Office of the Director Planning & Development, Dow University of Health Sciences (DMC Campus), 5th Floor Administration Block, Baba-e-Urdu Road near Civil Hospital Karachi.

DIRECTOR

Planning & Development
Dow University of Health Sciences, Karachi

INSTRUCTIONS TO BIDDERS

INSTRUCTION TO BIDDERS

A. GENERAL

IB.1 Scope of Bid

- 1.1 The Employer as defined below hereinafter called “the Employer” wishes to receive bids for the construction and completion works as described below and summarized referred to as the “Works”.

Name and Address of the Employer:

The Employer is “**DOW UNIVERSITY OF HEALTH SCIENCES, BABA-E-URDU ROAD, BESIDES CIVIL HOSPITAL, KARACHI,**”

Phone: (9221) 9921-6065-68 Fax No. (9221) 9921-6065

Name of the Project & Summary of the Works:

“ESTABLISHMENT OF PLASMA COLLECTION & PROCESSING FACILITY FOR BBMF DIABAR AT OJHA CAMPUS, DUHS, KARACHI.”

- 1.2 The successful bidder will be expected to complete the works within the time specified in Appendix-A to Bid.

IB.2 Source of Funds

- 2.1 The Employer has arranged funds from University Development Working Party (UDWP) and it is intended that part of the proceeds of this will be applied to eligible payments under the Contract for which these Bidding Documents are issued.

IB.3 Eligible Bidders

- 3.1 This invitation for Bids is open to all Bidders meeting the following requirements:
- a. Duly licensed by the Pakistan Engineering Council (PEC) in appropriate category / code and their license should be valid for the current calendar year.
 - b. Technically and Financially capable firm having adequate managerial capacity.
 - c. Valid Registration with FBR, SRB and NTN.

IB.4 One Bid per Bidder

- 4.1 Each bidder shall submit only one bid either by himself, or as a partner in a joint venture. A bidder who submits or participates in more than one bid (other than alternatives pursuant to Clause IB.16) will be disqualified.

IB.5 Cost of Bidding

- 5.1 The bidders shall bear all costs associated with the preparation and submission of their respective bids and the Employer will in no case be responsible or liable for those costs, regardless of the conduct or outcome of the bidding process.

B. BIDDING DOCUMENTS

IB.7 Contents of Bidding Documents

- 7.1 The Bidding Documents, in addition to invitation for bids, are those stated below and should be read in conjunction with any Addenda issued in accordance with Clause IB.9.
1. Instructions to Bidders.
 2. Bidding Data.
 3. General Conditions of Contract, Part-I (GCC).
 4. Particular Conditions of Contract, Part-II (PCC).
 5. Specifications – Special Provisions.
 6. Specifications - Technical Provisions.
 7. Form of Bid & Appendices to Bid.
 8. Bill of Quantities (Appendix-D to Bid).
 9. Form of Bid Security.
 10. Form of Contract Agreement.
 11. Drawings.
- 7.2 The bidders are expected to examine carefully the contents of all the above documents. Failure to comply with the requirements of bid submission will be at the Bidder's own risk. Pursuant to Clause IB.26, bids which are not substantially responsive to the requirements of the Bidding Documents will be rejected.

IB.8 Clarification of Bidding Documents

- 8.1 Any prospective bidder requiring any clarification (s) in respect of the Bidding Documents may notify the Employer in writing at the Employer's address indicated in the Invitation for Bids. The Employer will respond to any request for clarification which he receives earlier than (07) seven days prior to the deadline for submission of bids.

Copies of the Employer's response will be forwarded to all purchasers of the Bidding Documents, including a description of the enquiry but without identifying its source.

IB.9 Amendment of Bidding Documents

- 9.1 At any time prior to the deadline for submission of bids, the Employer may, for any reason, whether at his own initiative or in response to a clarification requested by a prospective bidder, modify the Bidding Documents by issuing addendum.
- 9.2 Any addendum thus issued shall be part of the Bidding Documents pursuant to Sub-Clause 7.1 hereof and shall be communicated in writing to all purchasers of the Bidding Documents. Prospective bidders shall acknowledge receipt of each addendum in writing to the Employer.
- 9.3 To afford prospective bidders reasonable time in which to take an addendum into account in preparing their bids, the Employer may extend the deadline for submission of bids in accordance with Clause IB.20

C. PREPARATION OF BIDS

IB.10 Language of Bid

- 10.1 The bid and all correspondence and documents related to the bid exchanged by a bidder and the Employer shall be in the bid language stipulated in the Bidding Data (English) and Particular Conditions of Contract. Supporting documents and printed literature furnished by the bidders may be in any other language provided the same are accompanied by an accurate translation of the relevant parts in the bid language, in which case, for purposes of evaluation of the bid, the translation in bid language shall prevail.

IB.11 Documents Accompanying the Bid

- 11.1 Each bidder shall:

- (a) submit a written power of attorney authorizing the signatory of the bid to act for and on behalf of the bidder;
- (b) update the information indicated and listed in the Bidding Data and previously submitted with the application for prequalification, and continue to meet the minimum criteria set out in the prequalification documents which as a minimum, would include the following:
 - (i) Evidence of access to financial resources along with average annual construction turnover;
 - (ii) Financial predictions for the current year and the two following years including the effect of known commitments;
 - (iii) Work commitments since prequalification;
 - (iv) Current litigation information; and
 - (v) Availability of critical equipment.
- (c) furnish a technical proposal taking into account the various Appendices to Bid specially the following:

Appendix-E to Bid Proposed Construction Schedule Appendix-F to Bid Method of Performing the Work Appendix-G to Bid List of Major Equipment Appendix-K to Bid Organization Chart for Supervisory Staff and other pertinent information.

- 11.2 Bids submitted by a joint venture of two (2) or more firms shall comply with the following requirements:

- (a) the bid and in case of a successful bid, the Form of Contract Agreement shall be signed so as to be legally binding on all partners;
- (b) one of the joint venture partners shall be nominated as being in charge; and this authorization shall be evidenced by submitting a power of attorney signed by legally authorized signatories of all the joint venture partners;
- (c) the partner-in-charge shall always be duly authorized to deal with the Employer regarding all matters related with and/or incidental to the execution of Works as per the terms and Conditions of Contract and in this regard to incur any and all liabilities, receive instructions, give binding undertakings and receive

- payments on behalf of the joint venture;
- (d) all partners of the joint venture shall at all times and under all circumstances be liable jointly and severally for the execution of the Contract in accordance with the Contract terms and a statement to this effect shall be included in the authorization mentioned under Sub-Para(b) above as well as in the Form of Bid and in the Form of Contract Agreement (in case of a successful bid); and
- (e) a copy of the agreement entered into by the joint venture partners shall be submitted with the bid stating the conditions under which it will function, its period of duration, the persons authorized to represent and obligate it and which persons will be directly responsible for due performance of the Contract and can give valid receipts on behalf of the joint venture, the proportionate participation of the several firms forming the joint venture, and any other information necessary to permit a full appraisal of its functioning. No amendments / modifications whatsoever in the joint venture agreement shall be agreed to between the joint venture partners without prior written consent of the Employer.

11.3 Bidders shall also submit proposals of work methods and schedule, in sufficient detail to demonstrate the adequacy of the Bidders' proposals to meet the technical specifications and the completion time referred to in Sub-Clause 1.2 hereof.

IB.12 Bid Prices

- 121 Unless stated otherwise in the Bidding Documents, the Contract shall be for the whole of the Works as described in Sub-Clause 1.1 hereof, based on the unit rates and / or prices submitted by the bidder.
- 122 The bidders shall fill in rates and prices for all items of the Works described in the Bill of Quantities. Items against which no rate or price is entered by a Bidder will not be paid for by the Employer when executed and shall be deemed covered by rates and prices for other items in the Bill of Quantities.
- 123 All duties, taxes and other levies payable by the Contractor under the Contract, or for any other cause, as on the date 28 days prior to the deadline for submission of bids shall be included in the rates and prices and the total Bid Price submitted by a bidder.
- Additional / reduced duties, taxes and levies due to subsequent additions or changes in legislation shall be reimbursed / deducted as per Sub-Clause 70.2 of the General Conditions of Contract Part-I.
- General Condition refer to page # 19-A
- 124 The rates and prices quoted by the bidders are subject to adjustment during the performance of the Contract in accordance with the provisions of Clause 70 of the Conditions of Contract. The bidders shall furnish the prescribed information for the price adjustment formulae in Appendix-C to Bid, and shall submit with their bids such other supporting information as required under the said Clause.

IB.13 Currencies of Bid and Payment

- 13.1 The unit rates and the prices shall be quoted by the bidder entirely in Pak rupees. The Employer shall make payment only in Pak Rupees and no foreign currency payments are admissible. A bidder expecting to incur expenditures in other currencies for inputs to the Works supplied from outside the Employer's country shall bear all the costs and risks for arranging the requirements of such currencies through his own resources.

IB.14 Bid Validity

- 14.1 Bids shall remain valid for the **90 Days** after the Date of Bid Opening specified in Clause IB.23.
- 14.2 In exceptional circumstances, prior to expiry of the original bid validity period, the Employer may request that the bidders extend the period of validity for a specified additional period which shall in no case be more than the original bid validity period. The request and the responses thereto shall be made in writing. A bidder may refuse the request without forfeiting his Bid Security. A bidder agreeing to the request will not be required or permitted to modify his bid, but will be required to extend the validity of his Bid Security for the period of the extension, and in compliance with Clause IB.15 in all respects.

IB.15 Bid Security

- 15.1 Each bidder shall furnish, as part of his bid, a Bid Security in the amount stipulated in the Bidding Data in Pak Rupees (2.5% of Bid Price in the form of Pay Order/ Bank Draft).
- 15.2 The Pay order shall be, at the option of the bidder, in the form of Deposit at Call or a Bank Guarantee issued by a Scheduled Bank in Pakistan or from a foreign bank duly counter guaranteed by a Scheduled Bank in Pakistan in favor of the Employer valid for a period 28 days beyond the Bid Validity date.
- 15.3 Any bid not accompanied by an acceptable Bid Security shall be rejected by the Employer as non-responsive.
- 15.4 The bid securities of unsuccessful bidders will be returned as promptly as possible, but not later than 28 days after the expiration of the period of Bid Validity.
- 15.5 The Bid Security of the successful bidder will be returned when the bidder has furnished the required Performance Security and signed the Contract Agreement.
- 15.6 The Bid Security may be forfeited:
- (a) if the bidder withdraws his bid except as provided in Sub-Clause 22.1;
 - (b) if the bidder does not accept the correction of his Bid Price pursuant to

Sub-Clause 27.2 hereof; or

- (c) In the case of successful bidder, if he fails within the specified time limit to:
 - (i) furnish the required Performance Security; or
 - (ii) sign the Contract Agreement.

IB.16 Alternate Proposals by Bidder

- 16.1 Alternate Proposals by bidder are not invited. Bidder will only quote for the drawings and Design as provided in the Bidding Documents

IB.17 ERRORS, OMISSIONS & QUERIES:

17.2 (a) The bidder shall notify “the Employer” of any inconsistencies, errors and omissions found in the Bid Documents, prior to the Bid Opening Date. Withholding of any such information which will later materially affect the contract price during construction may be considered as sufficient grounds for rejection of the Bid. All queries shall be directed to The Director (Planning & Development),

“ESTABLISHMENT OF PLASMA COLLECTION & PROCESSING FACILITY FOR BBMF DIABAR AT OJHA CAMPUS, DUHS, KARACHI.”

17.2 (b) The DUHS, Karachi is not responsible for any verbal communications or instructions to the bidders or Acceptable of the Bid Documents.

IB.18 Format and Signing of Bid

- 181 Bidders are particularly directed that the amount entered on the Form of Bid shall be for performing the Contract strictly in accordance with the Bidding Documents.
- 182 All appendices to Bid are to be properly completed and signed and stamped.
- 183 No alteration is to be made in the Form of Bid nor in the Appendices thereto except in filling up the blanks as directed. If any such alterations be made or if these instructions be not fully complied with, the bid may be rejected.
- 184 Each bidder shall prepare by filling out the forms completely and without alterations **one (1) original and one (1) copies**, specified in the Bidding Data, of the documents comprising the bid as described in Clause IB.7 and clearly mark them “ORIGINAL” and ‘COPY” as appropriate. In the event of discrepancy between them, the original shall prevail.
- 185 The original and all copies of the bid shall be typed or written in indelible ink (in the case of copies, Photostats are also acceptable) and shall be signed by a person or persons duly authorized to sign on behalf of the bidder pursuant to Sub- Clause 11.1(a) hereof. All pages of the bid shall be initialed and stamped by the person or persons signing the bid.
- 186 The bid shall contain no alterations, omissions or additions, except to comply with instructions issued by the Employer, or as are necessary to correct errors made by the bidder, in which case such corrections shall be initialed by the person or persons signing the bid.
- 187 Bidders shall indicate in the space provided in the Form of Bid their full and proper addresses at which notices may be legally served on them and to which all correspondence in connection with their bids and the Contract is to be sent.

Bids shall be prepared and submitted on the form of “the Bid “provided. All blank spaces must be filled in and completed form advance without interlineations or literation of the original wording. Bids with incomplete and /or unsigned Form of Bid may be rejected/ considered Non Responsive. The bidder shall stamp and sign each page of Bid Documents for the purpose of identification and acknowledgement of acceptance thereof. The bids must conform in all respects to the Bid Documents.

188 Bidders should retain a copy of the Bidding Documents as their file copy.

D. SUBMISSION OF BIDS

IB.19 Sealing and Marking of Bids

19.1 Each bidder shall submit his bid as under:

- (a) ORIGINAL and one (1) copy of the Bid shall be separately sealed and put in separate envelopes and marked as such.
- (b) The envelopes containing the ORIGINAL and copies will be put in one sealed envelope and addressed / identified as given in Sub- Clause 19.2 hereof.

19.2 The inner and outer envelopes shall:

- be addressed to the Director Planning & Development Department (DMC Campus), Baba-e- Urdu Road near Civil Hospital DUHS, Karachi; Phone/Fax:
 - (a) **Phone: (92-21)9921-6065**

Bear the name and identification number of the contract as defined in the Bidding Data; and **“ESTABLISHMENT OF PLASMA COLLECTION & PROCESSING FACILITY FOR BBMF DIABAR AT OJHA CAMPUS, DUHS, KARACHI.”**

- (b) provide a warning not to open before the time and date for bid opening, as specified in the Bidding Data.

19.3 In addition to the identification required in Sub- Clause 19.2 hereof, the inner envelope shall indicate the name and address of the bidder to enable the bid to be returned unopened in case it is declared “late” pursuant to Clause IB.21

19.4 Single Stage- One Envelope Procedure

- a) Notice inviting tenders and bidding documents of this method shall contain the following eligibility criteria:
 - i. Relevant experience;
 - ii. Turn-over of at least three years;
 - iii. Registration with Income Tax, Sales Tax, SRB and Pakistan Engineering Council
 - iv. Any other factor deemed to be relevant by the procuring agency subject to provision of Rule 44;
- b) Each bid shall comprise one single envelope containing the financial proposal and required information mentioned at clause (a) above;
- c) All bids received shall be opened and evaluated in the manner prescribed in the Notice Inviting Tenders or bidding Document

IB.20 Deadline for Submission of Bids

- 20.1 (a) Bids must be received by the Employer at the address specified no later than the time and date stipulated in the Bidding Data.
- (b) Bids with charges payable will not be accepted, nor will arrangements

be undertaken to collect the bids from any delivery point other than that specified above. Bidders shall bear all expenses incurred in the preparation and delivery of bids. No claims will be entertained for refund of such expenses.

- (c) Where delivery of a bid is by mail and the bidder wishes to receive an acknowledgment of receipt of such bid, he shall make a request for such acknowledgment in a separate letter attached to but not included in the sealed bid package.
- (d) Upon request, acknowledgment of receipt of bids will be provided to those making delivery in person or by messenger.

202 The Employer may, at his discretion, extend the deadline for submission of bids by issuing an amendment in accordance with Clause IB.9, in which case all rights and obligations of the Employer and the bidders previously subject to the original deadline will thereafter be subject to the deadline as extended.

IB.21 Late Bids

- 21.1 (a) Any bid received by the Employer after the deadline for submission of bids prescribed in Clause IB.20 will be returned unopened to such bidder.
- (b) Delays in the mail, delays of person in transit, or delivery of a bid to the wrong office shall not be accepted as an excuse for failure to deliver a bid at the proper place and time. It shall be the bidder's responsibility to determine the manner in which timely delivery of his bid will be accomplished either in person, by messenger or by mail.

IB.22 Modification, Substitution and Withdrawal of Bids

- 22.1 Any bidder may modify, substitute or withdraw his bid after bid submission provided that the modification, substitution or written notice of withdrawal is received by the Employer prior to the deadline for submission of bids.
- 22.2 The modification, substitution, or notice for withdrawal of any bid shall be prepared, sealed, marked and delivered in accordance with the provisions of Clause IB.19 with the outer and inner envelopes additionally marked "MODIFICATION", "SUBSTITUTION" or "WITHDRAWAL" as appropriate.
- 22.3 No bid may be modified by a bidder after the deadline for submission of bids except in accordance with Sub-Clauses 22.1 and 27.2.
- 22.4 Withdrawal of a bid during the interval between the deadline for submission of bids and the expiration of the period of bid validity specified in the Form of Bid may result in forfeiture of the Bid Security in pursuance to Clause IB.15.

E. BID OPENING AND EVALUATION

IB.23 Bid Opening

- 23.1 The Employer will open the bids, including withdrawals, substitution and modifications made pursuant to Clause IB.22, in the presence of bidders' representatives who choose to attend, at the time, date and location stipulated in

the Bidding Data. The bidders' representatives who are present shall sign a register evidencing their attendance.

- 23.2 Envelopes marked "MODIFICATION", "SUBSTITUTION" or "WITHDRAWAL" shall be opened and read out first. Bids for which an acceptable notice of withdrawal has been submitted pursuant to Clause IB.22 shall not be opened.
- 23.3 The bidder's name, total Bid Price and price of any Alternate Proposal(s), any discounts, bid modifications, substitution and withdrawals, the presence or absence of Bid Security, and such other details as the Employer may consider appropriate, will be announced by the Employer at the opening of bids.
- 23.4 The Consultant on behalf of Employer shall prepare minutes of the bid opening, including the information disclosed to those present in accordance with the Sub-Clause 23.3.

IB.24 Process to be Confidential

- 24.1 Information relating to the examination, clarification, evaluation and comparison of bid and recommendations for the award of a contract shall not be disclosed to bidders or any other person not officially concerned with such process. Any effort by a bidder to influence the Employer's processing of bids or award decisions may result in the rejection of such bidder's bid.

IB.25 Clarification of Bids

- 25.1 To assist in the examination, evaluation and comparison of bids, the Employer may, at his discretion, ask any bidder for clarification of his bid, including breakdowns of unit rates. The request for clarification and the response shall be in writing but no change in the price or substance of the bid shall be sought, offered or permitted except as required to confirm the correction of arithmetic errors discovered by the Employer in the evaluation of the bids in accordance with Clause IB.28.

IB.26 Examination of Bids and Determination of Responsiveness

- 26.1 Prior to the detailed evaluation of bids, the Employer will determine whether each bid is substantially responsive to the requirements of the Bidding Documents.
- 26.2 A substantially responsive bid is one which (i) meets the eligibility criteria; (ii) has been properly signed; (iii) is accompanied by the required Bid Security; and (iv) conforms to all the terms, conditions and specifications of the Bidding Documents, without material deviation or reservation. A material deviation or reservation is one (i) which affect in any substantial way the scope, quality or performance of the Works; (ii) which limits in any substantial way, inconsistent with the Bidding Documents, the Employer's rights or the bidder's obligations under the Contract; or (iii) adoption/rectification whereof would affect unfairly the competitive position of other bidders presenting substantially responsive bids.

- 26.3 If a bid is not substantially responsive, it will be rejected by the Employer, and may not subsequently be made responsive by correction or withdrawal of the non-conforming deviation or reservation.

IB.27 Correction of Errors

- 27.1 Bids determined to be substantially responsive will be checked by the Employer for any arithmetic errors. Errors will be corrected by the Employer as follows:
- (a) where there is a discrepancy between the amounts in figures and in words, the amount in words will govern; and
 - (b) where there is a discrepancy between the unit rate and the line item total resulting from multiplying the unit rate by the quantity, the unit rate as quoted will govern, unless in the opinion of the Employer there is an obviously gross misplacement of the decimal point in the unit rate, in which case the line item total as quoted will govern and the unit rate will be corrected.
- 27.2 The amount stated in the Form of Bid will be adjusted by the Employer in accordance with the above procedure for the correction of errors and with the concurrence of the bidder, shall be considered as binding upon the bidder. If the bidder does not accept the corrected Bid Price, his Bid will be rejected, and the Bid Security shall be forfeited in accordance with Sub- Clause 15.6(b) hereof.

IB.28 Evaluation and Comparison of Bids

- 28.1 The Employer will evaluate and compare only the Bids determined to be substantially responsive in accordance with Clause IB.26.
- 28.2 In evaluating the Bids, the Employer will determine for each Bid the evaluated Bid Price by adjusting the Bid Price as follows:
- (a) making any correction for errors pursuant to Clause IB.27;
 - (b) excluding Provisional Sums and the provision, if any, for contingencies in the Summary Bill of Quantities, but including competitively priced Day work; and
 - (c) making an appropriate adjustment for any other acceptable variation or deviation.
- 28.3 The estimated effect of the price adjustment provisions of the Conditions of Contract, applied over the period of execution of the Contract, shall not be taken into account in Bid evaluation.
- 28.4 If the Bid of the successful bidder is seriously unbalanced in relation to the Employer's estimate of the cost of work to be performed under the Contract, the Employer may require the bidder to produce detailed price analyses for any or all items of the Bill of Quantities to demonstrate the internal consistency of those prices with the construction methods and schedule proposed. After evaluation of the price analyses, the Employer may require that the amount of the

Performance Security set forth in Clause IB.32 be increased at the expense of the successful bidder to a level sufficient to protect the Employer against financial loss in the event of default of the successful bidder under the Contract.

- 28.5 A bid with highly inflated or unworkable rates of any BOQ items may be considered non-conforming and rejected. The Employer may also disqualify such bidder from participating in the subsequent bids who submits such unbalanced and/or unworkable rates of major items of work.

F. AWARD OF CONTRACT

IB.29 Award

- 29.1 Subject to Clauses IB.30 and IB.34, the Employer will award the Contract to the bidder whose bid has been determined to be substantially responsive to the Bidding Documents and who has offered the lowest evaluated Bid Price, Provided that such bidder has been determined to be eligible in accordance with the provisions of Clause IB.3 and qualify pursuant to Sub-Clause IB 29.2.

- 29.2 The Employer, at any stage of the bid evaluation, having credible reasons for or *prima facie* evidence of any defect in supplier's or contractor's capacities, may require the suppliers or contractors to provide information concerning their professional, technical, financial, legal or managerial competence whether already pre-qualified or not:

Provided that such qualification shall only be laid down after recording reasons therefor in writing. They shall form part of the records of that bid evaluation report.

IB.30 Employer's Right to accept any Bid and to reject any or all Bids

- 30.1 Notwithstanding Clause IB.29, the Employer reserves the right to accept or reject any Bid, and to annul the bidding process and reject all bids, at any time prior to award of Contract, without thereby incurring any liability to the affected bidders or any obligation except that the grounds for rejection of all bids shall upon request be communicated to any bidder who submitted a bid, without justification of grounds. Rejection of all bids shall be notified to all bidders promptly.

IB.31 Notification of Award

- 31.1 Prior to expiration of the period of bid validity prescribed by the Employer, the Employer will notify the successful bidder in writing ("Letter of Acceptance") that his Bid has been accepted. This letter shall name the sum which the Employer will pay the Contractor in consideration of the execution and completion of the Works by the Contractor as prescribed by the Contract (hereinafter and in the Conditions of Contract called the "Contract Price").
- 31.2 No Negotiation with the bidder having evaluated as lowest responsive or any other bidder shall be permitted, however, Employer may have clarification meetings to get clarify any item in the bid evaluation report.

- 31.3 The notification of award and its acceptance by the bidder will constitute the formation of the Contract, binding the Employer and the bidder till signing of the formal Contract Agreement.
- 31.3 Upon furnishing by the successful bidder of a Performance Security, the Employer will promptly notify the other bidders that their Bids have been unsuccessful and return their bid securities.

IB.32 Performance Security

- 32.1 The performance security shall be equal to an amount of 10% of the contract Price stated in the Letter of Acceptance. Such Security shall be in the Form of Pay order/irrevocable Bank Guarantee from any scheduled Bank of Pakistan acceptable to the Employer in favor of Dow University of Health Sciences, Karachi. The performance security will be valid for a period (up to the completion of the Project) after the date of issue of Defect Liability Certificate.
- 32.2 Failure of the successful bidder to comply with the requirements of Sub-Clause IB.32.1 or Clauses IB.33 or IB.35 shall constitute sufficient grounds for the annulment of the award and forfeiture of the Bid Security.

IB.33 Signing of Contract Agreement

- 33.1 Within 14 days from the date of furnishing of acceptable Performance Security under the Conditions of Contract, the Employer will send the successful bidder the Contract Agreement in the form provided in the Bidding Documents, incorporating all agreements between the parties.
- 33.2 The formal Agreement between the Employer and the successful bidder shall be executed within 14 days of the receipt of the Contract Agreement by the successful bidder from the Employer.

IB.34 General Performance of the Bidders

The Employer reserves the right to obtain information regarding performance of the bidders on their previously awarded contracts/works. The Employer may in case of consistent poor performance of any Bidder as reported by the employers of the previously awarded contracts, interilic, reject his bid and/or refer the case to the Pakistan Engineering Council (PEC). Upon such reference, PEC in accordance with its rules, procedures and relevant laws of the land take such action as may be deemed appropriate under the circumstances of the case including black listing of such Bidder and debarring him from participation in future bidding for similar works.

IB.35 Integrity Pact

The Bidder shall sign and stamp the Integrity Pact provided at Appendix-L to Bid in the Bidding Documents for all Federal Government procurement contracts exceeding Rupees ten million. Failure to provide such Integrity Pact shall make the bidder non-responsive.

IB.36 Instructions not Part of Contract

Bids shall be prepared and submitted in accordance with these Instructions which are provided to assist bidders in preparing their bids, and do not constitute part of the Bid or the Contract Documents.

BIDDING DATA

[NOTES ON BIDDING DATA]

This Section is intended to assist the Employer in providing the specific information in relation to corresponding clauses in Instructions to Bidders and should be prepared to suit each individual contract.

The Employer should provide in the Bidding Data information and requirements specific to the circumstances of the Employer, the processing of the Bid, the applicable rules regarding Bid Price and currency, and the Bid evaluation criteria that will apply to the Bids. In preparing this section, the following aspects should be checked:

- (a) Information that specifies and complements the provisions of section; Instruction to Bidders must be incorporated.
- (b) Amendments and/or supplements, if any, to the provisions of Instructions to Bidders, necessitated by the circumstances of each individual contract, can be introduced only in this section since Instructions to Bidders will remain unchanged.]

Bidding Data

1.1 Name and address of the Employer:

The Employer is Dow University of Health Sciences, Karachi
Phone / Fax: (9221) 9921-6065

Name of the Project & Summary of the Works:

**“ESTABLISHMENT OF PLASMA COLLECTION & PROCESSING FACILITY FOR
BBMF DIABAR AT OJHA CAMPUS, DUHS, KARACHI.”**

The work involves execution of Civil, Electrical, Plumbing, Data / IT, Clean Room, CCTV, Fire Works, and allied Works in accordance with the design, Drawings, Technical Specifications, Bill of Quantities and Instructions of the Client/ Consultant with special emphasis on Quantity and Quality control ethics.

IB.2 Source of Funds:

The Employer has arranged funds from University Development Working Party (UDWP) and it is intended that part of the proceeds of this will be applied to eligible payments under the Contract for which these Bidding Documents are issued.

IB.3 Eligible Bidders

As notified in NIT and Bidding Document.

IB.8.1 Time limit for clarification:

The Employer will respond to any request for clarification which he receives earlier than (07) Seven Days prior to the deadline for submission of bids

IB.10 Bid language:

The bid and all correspondence and documents related to the bid exchanged by a bidder and the Employer shall be in the English Language.

IB.11.1(c) Furnish Technical Proposal:

The bidder to submit a technical proposal in sufficient detail to demonstrate the adequacy of the bid in meeting requirements for timely completion of the Works and taking into account the various appendices to Bid specified into instructions to Bidder.

IB.13.1 Currencies of Bid and Payment

The unit rates and the prices shall be quoted by the bidder entirely in Pak rupees. The Employer shall make payment only in Pak Rupees and no foreign currency payments are admissible. A bidder expecting to incur expenditures in other currencies for inputs to the Works supplied from outside the Employer's country shall bear all the costs and risks for arranging the requirements of such currencies through his own resources.

IB.14.1 Period of Bid Validity:

Bids shall remain valid for the **90** Days after the date of bid opening.

IB.15.1 Amount of Bid Security:

Minimum **2.5%** of Bid Price in the form of Pay Order/ Bank Draft

IB.18.4 Number of copies of the Bid to be completed and submitted:

One (1) original and one copies must be submitted.

IB.19 Sealing and Marking of Bids**19.2(a) Employer's address for the purpose of Bid Submission**

5TH Floor administration building DMC Campus, Office of the Project
Account Officer at Planning & Development Department (DMC Campus),
Baba-e- Urdu Road near Civil Hospital DUHS, Karachi; Phone/Fax:
(92-21)99216065

19.2 (a) (b) Name and number of the Contract

Bear the contract name

**“ESTABLISHMENT OF PLASMA COLLECTION & PROCESSING FACILITY FOR
BBMF DIABAR AT OJHA CAMPUS, DUHS, KARACHI.”**

IB. 20.1(a) Deadline for submission of bids:

As notified in “Invitation to Bids”

IB. 23.1 Venue, Time and Date of Bid opening:

As notified in “Invitation to Bids”

I.B.32.1 Standard form and amount of Performance Security acceptable to the Employer:

The performance security shall be equal to an amount of **10%** of the contract Price stated in the Letter of Acceptance. Such Security shall be in the Form of unconditional, irrevocable Bank Guarantee from any scheduled Bank of Pakistan acceptable to the Employer in favor of Dow University of Health Sciences. The performance security will be valid for a period (up to the completion of the Project) after the date of issue of Defect Liability Certificate.

Contract/Bidding Data

The following specific data for the works to be tendered shall complement, amend, or supplement the provisions in the Instructions to Bidders. Wherever there is a conflict, the provisions herein shall prevail over those in the Instructions to Bidders.

Instructions to Bidders

Clause Reference

- 1.1.1 Name and address of the procuring agency:
Office of the Director Planning & Development Department (DMC Campus)
Bab-e- Urdu Road near Civil Hospital DUHS,
Phone: (92-21)38771000 (Ext: 5820)
- 1.2 Name of the Project and Summary of the works:
**“ESTABLISHMENT OF PLASMA COLLECTION & PROCESSING FACILITY FOR
BBMF DIABAR AT OJHA CAMPUS, DUHS, KARACHI.”**
- 8.1 Time limit for clarification:
07 (Seven) working days prior to last date of submission
- 10.1 Bid language:
English
- 11.1 (a) Prequalification Information to be updated (where applicable):
Not applicable
- 11.1 (b) Furnish Company Profile for Single Stage One Envelope:
Following are minimum Mandatory requirement
- i. The bidder must have done at least five (05) contracts of similar nature in last 07 years preferably of building hospitals or education building. (Please submit copy of PO/Contract / Agreement / Notification of Award / Completion Certificate).
 - ii. The bidder must have turnover/sales exceeding 200 Million in PKR annually in any of last three years (Submission of Audited Annual Reports or reputable bank letter or bank statement of any last three years.
 - iii. Bidder must submit undertaking on 100/- legal stamp paper confirming he is not declared black listed by any procuring agency of Pakistan if proved blacklisted his bid security shall be forfeited.
 - iv. Bidder must submit valid NTN, GST and SRB registration number or copy of certificates.
 - v. PEC Registration in at least category C4 with the following codes CE01, CE09, CE10, BC01, BC02, ME02, ME07(v), EE01, EE02, EE04, EE07, EE08, EE10, EE11(vi) (MANDATORY)
 - vi. Envelopes shall be marked as “Original” and Copy ” in bold and legible letters to avoid confusion; one (1) original and one (1) copies. The document should be separately clearly marking each “ORIGINAL BID” and “COPY OF BID,” as appropriate. In the event of any discrepancy between them, the original shall govern
- 32.3 Stamp duty
0.35% will be paid by successful bidder as stamp duty.

**FORM OF BID
AND
APPENDICES TO BID**

FORM OF BID

Bid Reference No. _____
 (Name of Contract/Works)

To:

Gentleman, _____

1. Having examined the Bidding Documents including Instructions to Bidders, Bidding Data, Conditions of Contract. Specifications, Drawings and Bill of Quantities and Addenda Nos. _____ for the execution of the above-named Works, we, the undersigned, offer to execute and complete such Works and remedy any defects therein in conformity with the Conditions of Contract. Specifications, Drawings, Bill of Quantities and Addenda for the sum of Rs. _____ (Rupees _____) or such other sum as may be ascertained in accordance with the said conditions.
2. We understand that all the Appendices attached hereto form part of this Bid.
3. As security for due performance of the undertakings and obligations of this Bid, we submit herewith a Bid Security in the amount of Rupees _____ (Rs. _____) drawn in your favor or made payable to you and valid for a period of _____ days beginning from the date Bids are opened.
4. We undertake, if our Bid is accepted, to commence the Works and to complete the whole of the Works comprised in the Contract within the time stated in Appendix-A to Bid.
5. We agree to abide by this Bid for the period of _____ days from the date fixed for receiving the same and it shall remain binding upon us and may be accepted at any time before the expiration of that period.
6. Unless and until a formal Agreement is prepared and executed, this Bid, together with your written acceptance thereof, shall constitute a binding contract between us.
7. We do hereby declare that the Bid is made without any collusion, comparison of figures or arrangement with any other bidder for the Works.

- 8. We understand that you are not bound to accept the lowest or any Bid you may receive.

Dated this _____ day of _____ 20 _____

Signature: _____

in the capacity of _____ duly authorized to sign Bids for and on behalf of

Bidder in Block Capitals) (Seal)

Address: _____

Witness:

Signature: _____

Name: _____

Address. _____

Occupation

BIDDING DATA

The following specific data for the works to be procured shall complement, supplement or amend the provisions in the terms & Conditions of bidding documents.

Whenever there is a conflict, the provisions herein shall prevail over those in terms & conditions of the bidding documents.

Terms and Conditions of Contract

1	Name of Procuring Agency:	Dow University of Health Sciences, DMC Campus Baba-e-Urdu Road Near Civil Hospital Karachi.
2	Brief Description of Works:	Establishment of Plasma Collection & Processing facility for BBMF Diabar at Ojha campus, DUHS, Karachi.
3	Amount of Bid Security	2.5% Amount in shape of Deposit at Call or Pay Order demand Draft or a bank Guarantee in favor of Dow University of Health Sciences, Karachi Issued by a Scheduled bank in Pakistan
4	Amount of Performance Security	5% of the Contract price. Total amount including Performance Security and retention money deducted from bills 5% of contract price stated in Letter of Acceptance.
5	Period of Bid Validity (Days)	90 Days
6	Percentage of Retention Money	5% of the amount of the Interim / Running Payment Certificate.
7	Venue, Time and Date of Bid Opening	As Notified in NIT
8	Deadline for Submission of Bid along with time:	As Notified in NIT
9	Currency of Bid:	Pakistani Rupees.
10	Time for furnishing Program	Within 14 Days from the date of receipt of Letter of Acceptance.
11	Time for Commencement	Within 07 days from the date of receipt of Engineer's Notice to Commence.
12	Time for Completion of Works	06 (Six) months from the date of receipt of Engineer's Notice to Commence.
13	Amount of Liquidity Damages/Delay Damages /Penalties	One tenth of one percent (0.10%) for each day of delay in completion of the Works subject to a maximum of 10% of Contract Price and after that termination of contract after 07 days' Notice.
14	Defects Liability Period	180 days from the effective date of Taking Over Completion Certificate.

BILL OF QUANTITIES

A. Preamble

1. The Bill of Quantities shall be read in conjunction with the Conditions of Contract, Specifications and Drawings.
2. The quantities given in the Bill of Quantities are estimated and provisional, and are given to provide a common basis for bidding. The basis of payment will be the actual quantities of work executed and measured by the Contractor and verified by the Engineer and valued at the rates and prices entered in the priced Bill of Quantities, where applicable, and otherwise at such rates and prices as the Engineer may fix as per the Contract.
3. The rates and prices entered in the priced Bill of Quantities shall, except insofar as it is otherwise provided under the Contract include all costs of Contractor's plant, labor, supervision, materials, execution, insurance, profit, taxes and duties, together with all general risks, liabilities and obligations set out or implied in the Contract. Furthermore, all duties, taxes and other levies payable by the Contractor under the Contract, or for any other cause, as on the date 28 days prior to deadline for submission of Bids, shall be included in the rates and prices and the total Bid Price submitted by the Bidder.
4. A rate or price shall be entered against each item in the priced Bill of Quantities, whether quantities are stated or not. The cost of items against which the Contractor will have failed to enter a rate or price shall be deemed to be covered by other rates and prices entered in the Bill of Quantities.
5. The whole cost of complying with the provisions of the Contract shall be included in the items provided in the priced Bill of Quantities, and where no items are provided, the cost shall be deemed to be distributed among the rates and prices entered for the related items of the Works.
6. General directions and description of work and materials are not necessarily repeated nor summarized in the Bill of Quantities. References to the relevant sections of the Bidding Documents shall be made before entering prices against each item in the priced Bill of Quantities.
7. Provisional sums included and so designated in the Bill of Quantities shall be expended in whole or in part at the direction and discretion of the Engineer in accordance with Sub-Clause 58.2 of Part I, General Conditions of Contract.

BILL OF QUANTITIES

B. Work Items

1. The Bill of Quantities contains the following Bills and Schedule:
(by way of example)

Bill No. 1	-
Bill No. 2	-
Bill No. 3	-
Bill No. 4	-
Bill No. 5	-
Day work Schedule	
Summary Bill of Quantities	

2. Bidders shall price the Bill of Quantities in Pakistani Rupees only.

BILL OF QUANTITIES

Bill No.1 _____

	Description	Unit	Quantity	Rate		Amount
				Rupees in figures	Rupees in Word	
1	2	3	4	5		6
101						
102						
103						
104						
105						
106						
Total for Bill No.1 (Carried Forward to Summary Page) _____						

BILL OF QUANTITIES

C. Day work

Schedule General

1. Reference is made to Sub-Clause 52.4 of the General Conditions of Contract Part-I. Work shall not be executed on a day work basis except by written order of the Engineer. Bidders shall enter basic rates for Day work items in the Schedules, which rates shall apply to any quantity of Day work ordered by the Engineer. Nominal quantities have been indicated against each item of Day work, and the extended total for Day work shall be carried forward to the Bid Price.

Day work Labor

2. In calculating payments due to the Contractor for the execution of Day work, the actual time of classes of labor directly doing the Day work ordered by the Engineer and for which they are competent to perform will be measured excluding meal breaks and rest periods. The time of gingers (charge hands) actually doing work with the gang will also be measured but not the time of foreman or other supervisory personnel.
3. The Contractor shall be entitled to payment in respect of the total time that labor is employed on Day work, calculated at the basic rates entered by him in the Schedule of Day work Rates for labor together with an additional percentage, payment on basic rates representing the Contractor's profit, overheads, etc., as described below:
 - a) the basic rates for labor shall cover all direct costs to the Contractor, including (but not limited to) the amount of wages paid to such labor, transportation time, overtime, subsistence allowances and any sums paid to or on behalf of such labor for social benefits in accordance with Pakistan law. The basic rates will be payable in local currency only; and
 - b) the additional percentage payment to be quoted by the Bidder and applied to costs incurred under (a) above shall be deemed to cover the Contractor's profit, overheads, superintendence, liabilities and insurances and allowances to labor timekeeping and clerical and office work; the use of consumable stores, water, lighting and power; the use and repair of staging, scaffolding, workshops and stores, portable power tools, manual plant and tools; supervision by the Contractor's staff, foremen and other supervisory personnel; and charges incidental to the foregoing.

Day work Material

4. The Contractor shall be entitled to payment in respect of materials used for Day work (except for materials for which the cost is included in the percentage addition to labor costs as detailed heretofore), at the basic rates entered by him in the Schedule of Day work Rates for materials together with an additional percentage payment on the basic rates to cover overhead charges and profit, as follows:
 - a) The basic rates for materials shall be calculated on the basis of the invoiced price, freight, insurance, handling expenses, damage, losses, etc., and shall provide for delivery to store for stockpiling at the site. The basic rates shall be stated in local currency but payment will be made in the currency or currencies expended upon presentation of supporting documentation;
 - b) the additional percentage payment shall be quoted by the Bidder and applied to the equivalent local currency payments made under Sub-Para(a) above; and
 - c) the cost of hauling materials used on work ordered to be carried out as Day work from the store or stockpile on the site to the place where it is to be used will be paid in accordance with the terms for Labor and Constructional Plant in this Schedule.

Day work Constructional Plant

5. The Contractor shall be entitled to payments in respect of constructional plant already on Site and employed on Day work at the basic rental rates entered by him in the Schedule of Day work Rates for constructional plant. The said rates shall be deemed to include complete allowance for depreciation, interest, indemnity and insurance, repairs, maintenance, supplies, fuel, lubricants, and other consumables, and all overhead, profit and administrative costs related to the use of such equipment. The cost of drivers, operators and assistants will be paid for separately as described under the section on Day work Labor.
6. In calculating the payment due to the Contractor for constructional plant employed on Day work, only the actual number of working hours will be eligible for payment, except that where applicable and agreed with the Engineer, the travelling time from the part of the Site where the constructional plant was located when ordered by the Engineer to be employed on Day work and the time for return journey thereto shall be included for payment.
7. The basic rental rates for constructional plant employed on Day work shall be stated in Pakistani Rupees.

PROPOSED CONSTRUCTION SCHEDULE

Pursuant to Sub-Clause 43.1 of the General Conditions of Contract, the Works shall be completed on or before the date stated in Appendix-A to Bid. The Bidder shall provide as Appendix-E to Bid, the Construction Schedule in the bar chart (CPM, PERT or any other to be specified herein) showing the sequence of work items and the period of time during which he proposes to complete each work item in such a manner that his proposed programme for completion of the whole of the Works and parts of the Works may meet Employer's completion targets in days noted below and counted from the date of receipt of Engineer's Notice to Commence (Attach sheets as required for the specified form of Construction Schedule):

A) ESTABLISHMENT OF PLASMA COLLECTION & PROCESSING FACILITY FOR BBMF
DIABAR

CONSTRUCTION SCHEDULE

<u>Description</u>	<u>Time for Completion</u>
Whole Works of Plasma Collection (A)	_____ days
a) Part-A (CIVIL / ARCHITECTURAL WORK)	_____ days
b) Part-B (PLUMBING WORK)	_____ days
c) Part-C (EXTERNAL DEVELOPMENT WORK AND OTHER MISCELLANEOUS WORKS)	_____ days
d) Part-D (CLEAN ROOM WORK)	_____ days
e) Part-E (ELECTRICAL WORK)	_____ days
f) Part-F (DATA / IT WORK)	_____ days
g) Part-G (CCTV WORK)	_____ days
h) Part-H (FIRE ALARM WORK)	_____ days

METHOD OF PERFORMING THE WORK

[The Bidder is required to submit a narrative outlining the method of performing the Work. The narrative should indicate in detail and include but not be limited to:

1. Organization Chart indicating head office and field office personnel involved in management and supervision, engineering, equipment maintenance and purchasing.
2. Mobilization in Pakistan, the type of facilities including personnel accommodation, office accommodation, provision for maintenance and for storage, communications, security and other services to be used.
3. The method of executing the Works, the procedures for installation of equipment and machinery and transportation of equipment and materials to the site.]

LIST OF MAJOR EQUIPMENT – RELATED ITEMS

[The Bidder will provide on Sheet 2 of this Appendix a list of all major equipment and related items, under separate heading for items owned, to be purchased or to be arranged on lease by him to carry out the Works. The information shall include make, type, capacity, and anticipated period of utilization for all equipment which shall be in sufficient detail to demonstrate fully that the equipment will meet all requirements of the Specifications.]

LIST OF MAJOR EQUIPMENT

Owned Purchased or Leased	Description of Unit (Make, Model, Year)	Capacity HP Rating	Condition	Present Location or Source	Date of Delivery at Site	Period of Work on Project
1	2	3	4	5	6	7
a. Owned						
b. To be Purchased						
c. To be arranged on Lease						

CONSTRUCTION CAMP AND HOUSING FACILITIES

The Contractor in accordance with Clause 34 of the Conditions of Contract shall provide description of his construction camp's facilities and staff housing requirements.

The Contractor shall be responsible for pumps, electrical power, water and electrical distribution systems, and sewerage system including all fittings, pipes and other items necessary for servicing the Contractor's construction camp.

The Bidder shall list or explain his plans for providing these facilities for the service of the Contract as follows:

1. Site Preparation (clearing, land preparation, etc.).
2. Provision of Services.
 - a) Power (expected power load, etc.).
 - b) Water (required amount and system proposed).
 - c) Sanitation (sewage disposal system, etc.).
3. Construction of Facilities
 - a) Contractor's Office. Workshop and Work Areas (areas required and proposed layout, type of construction of buildings, etc.).
 - b) Warehouses and Storage Areas (area required, type of construction and layout).
 - c) Housing and Staff Facilities (Plans for housing for proposed staff, layout, type of construction, etc.).
4. Construction Equipment Assembly and Preparation (detailed plans for carrying out this activity).
5. Other Items Proposed (Security services, etc.)
6. The Contractor's responsibility to arrange the water for construction work or wherever water require for the execution of work. The client will not provide the water and contractor arrange outside from the university premises on his own basis. Before use water, contractor should submit the test report from PCSIR laboratory.
7. Contractor will arrange electricity source on its own basis or use an alternate of source of electricity (like Generator) or contractor can take temporary connection from university. Connection would be on sub meter. Contractor will liable to pay bill to university for the temporary connection.

**ORGANIZATION
CHART FOR THE
SUPERVISORY STAFF**

(INTEGRITY PACT)
DECLARATION OF FEES, COMMISSION AND BROKERAGE ETC.
PAYABLE BY CONTRACTORS.

(FOR CONTRACTS WORTH RS. 10.00 MILLION OR MORE)

Contract No. _____ Dated _____

Contract Value: _____

Contract Title: _____

_____ (Name of Contractor) hereby declares that it has not obtained or induce the procurement of any contract, right, interest, privilege or other obligation or benefit from government of Sindh (GoS) or any administrative subdivision or agency thereof any other entity owned or controlled by it (GoS) through any corrupt business practice.

Without limiting the generality of the foregoing (Name of contractor) represents and warrants that it has fully declared the brokerage, commission, fees etc. paid or payable to anyone and not given or agreed to give and shall not give or agree to give to anyone within or outside Pakistan – either directly or indirectly through any natural judicial person, including its affiliate, agent, associate, broker, consultant, director, promoter, shareholder, sponsor or subsidiary, any commission gratification, bribe, finder's fee or kickback, whether described as consultation fee or otherwise, with the object of obtaining or including the procurement of a contract, right, interest privilege or other obligation or benefits in whatsoever from, procuring agency (PA) except that has been expressly declared pursuant hereto.

(Name of Contractor) accepts full responsibility and strict liability that it has made and will make full disclosure of all agreements and arrangements with all person in respect of or related to the transaction with PA and has not taken any action or will not take any action to circumvent the above declaration, representation or warranty. (Name of Contractor) accepts full responsibilities and strict liability for making any false declaration, not making full disclosure, misrepresenting facts or taking any action likely to defeat the purpose of declaration, representation and warranty. It agrees that any contract, right, interest, privilege or other obligation or benefit obtained or procured as aforesaid shall, without prejudice to any rights and remedies available to PA under any law, contract or other instrument, be voidable at the option of PA.

Notwithstanding any rights and remedies exercised by PA in this regards, (Name of supplier/Contractor/Consultant) agrees to indemnify PA for any loss or damage incurred by it on account of its corrupt business practices and further pay compensation to PA in an amount equivalent to ten time the sum of any commission, gratification, bribe, finder's fee or kickback given by (name of contractor) as aforesaid for purpose of obtaining or including the procurement of any contract, right, interest, privilege or other obligation or benefit in whatsoever form from PA.

(PROCURING AGENCY)

(CONTRACTOR)

FORMS

**BID SECURITY
PERFORMANCE SECURITY
CONTRACT AGREEMENT**

BID SECURITY
(Bank Guarantee)

Security Executed on _____
(Date)

Name of Surety (Bank) with Address: _____
(Scheduled Bank in Pakistan)

Name of Principal (Bidder) with Address _____

Penal Sum of Security Rupees. _____ (Rs. _____)

Bid Reference No. _____

KNOW ALL MEN BY THESE PRESENTS, that in pursuance of the terms of the Bid and at the request of the said Principal (Bidder) we, the Surety above named, are held and firmly bound unto _____

(hereinafter called the 'Employer') in the sum stated above for the payment of which sum well and truly to be made, we bind ourselves, our heirs, executors, administrators and successors, jointly and severally, firmly by these presents.

THE CONDITION OF THIS OBLIGATION IS SUCH, that whereas the Bidder has submitted the accompanying Bid dated _____ for Bid No. _____ for _____ (Particulars of Bid) to the said Employer; and

WHEREAS, the Employer has required as a condition for considering said Bid that the Bidder furnishes a Bid Security in the above said sum from a Scheduled Bank in Pakistan or from a foreign bank duly counter-guaranteed by a Scheduled Bank in Pakistan, to the Employer, conditioned as under:

- (1) that the Bid Security shall remain in force up to and including the date 28 days after the deadline for validity of bids as stated in the Instructions to Bidders or as it may be extended by the Employer, notice of which extension(s) to the Surety is hereby waived;
- (2) that the Bid Security of unsuccessful Bidders will be returned by the Employer after expiry of its validity or upon signing of the Contract Agreement; and
- (3) that in the event of failure of the successful Bidder to execute the proposed Contract Agreement for such work and furnish the required Performance Security, the entire said sum be paid immediately to the said Employer pursuant to Clause 15.6 of the Instruction to Bidders for the successful Bidder's failure to perform.

NOW THEREFORE, if the successful Bidder shall, within the period specified therefor, on the prescribed form presented to him for signature enter into a formal Contract with the said Employer in accordance with his Bid as accepted and furnish within twenty eight (28) days of his being requested to do so, a Performance Security with good and sufficient surety, as may be required, upon the form prescribed by the said Employer for the faithful performance and proper fulfilment of the said Contract or in the event of non-withdrawal of the said Bid within the time specified for its validity then this obligation shall be void and of no effect, but otherwise to remain in full force and effect.

PROVIDED THAT the Surety shall forthwith pay the Employer the said sum upon first written demand of the Employer (without cavil or argument) and without requiring the Employer to prove or to show grounds or reasons for such demand, notice of which shall be sent by the Employer by registered post duly addressed to the Surety at its address given above.

PROVIDED ALSO THAT the Employer shall be the sole and final judge for deciding whether the Principal (Bidder) has duly performed his obligations to sign the Contract Agreement and to furnish the requisite Performance Security within the time stated above, or has defaulted in fulfilling said requirements and the Surety shall pay without objection the said sum upon demand from the Employer forthwith and without any reference to the Principal (Bidder) or any other person.

IN WITNESS WHEREOF, the above bounden Surety has executed the instrument under its seal on the date indicated above, the name and seal of the Surety being hereto affixed and these presents duly signed by its undersigned representative pursuant to authority of its governing body.

SURETY (Bank)

WITNESS:

Signature _____

1. _____

Name _____

Title _____

Corporate Secretary (Seal)

Corporate Guarantor (Seal)

2. _____

Name, Title & Address

**FORM OF PERFORMANCE SECURITY
(Bank Guarantee)**

Guarantee No. _____
Executed on _____
Expiry date _____

[Letter by the Guarantor to the Employer]

Name of Guarantor (Bank) with address: _____
(Scheduled Bank in Pakistan)

Name of Principal (Contractor) with address: _____

Penal Sum of Security (express in words and figures) _____

Letter of Acceptance No. _____ Dated _____

KNOW ALL MEN BY THESE PRESENTS, that in pursuance of the terms of the Bidding Documents and above said Letter of Acceptance (hereinafter called the Documents) and at the request of the said Principal we, the Guarantor above named, are held and firmly bound unto the _____ (hereinafter called the Employer) in the penal sum of the amount stated above for the payment of which sum well and truly to be made to the said Employer, we bind ourselves, our heirs, executors, administrators and successors, jointly and severally, firmly by these presents.

THE CONDITION OF THIS OBLIGATION IS SUCH, that whereas the Principal has accepted the Employer's above said Letter of Acceptance for _____ (Name of Contract) for the _____ (Name of Project).

NOW THEREFORE, if the Principal (Contractor) shall well and truly perform and fulfill all the undertakings, covenants, terms and conditions of the said Documents during the original terms of the said Documents and any extensions thereof that may be granted by the Employer, with or without notice to the Guarantor, which notice is, hereby, waived and shall also well and truly perform and fulfill all the undertakings, covenants terms and conditions of the Contract and of any and all modifications of said Documents that may hereafter be made, notice of which modifications to the Guarantor being hereby waived, then, this obligation to be void; otherwise to remain in full force and virtue till all requirements of Clause 49, Defects Liability, of Conditions of Contract are fulfilled.

Our total liability under this Guarantee is limited to the sum stated above and it is a condition of any liability attaching to us under this Guarantee that the claim for payment in writing shall be received by us within the validity period of this Guarantee, failing which we shall be discharged of our liability, if any, under this Guarantee.

We, _____ (the Guarantor), waiving all objections and defenses under the Contract, do hereby irrevocably and independently guarantee to pay to the Employer without delay upon the Employer's first written demand without cavil or arguments and without requiring the Employer to prove or to show grounds or reasons for such demand any sum or sums up to the amount stated above, against the Employer's written declaration that the Principal has refused or failed to perform the obligations under the Contract which payment will be effected by the Guarantor to Employer's designated Bank & Account Number.

PROVIDED ALSO THAT the Employer shall be the sole and final judge for deciding whether the Principal (Contractor) has duly performed his obligations under the Contract or has defaulted in fulfilling said obligations and the Guarantor shall pay without objection any sum or sums up to the amount stated above upon first written demand from the Employer forthwith and without any reference to the Principal or any other person.

IN WITNESS WHEREOF, the above-bounden Guarantor has executed this Instrument under its seal on the date indicated above, the name and corporate seal of the Guarantor being hereto affixed and these presents duly signed by its undersigned representative, pursuant to authority of its governing body.

	_____ Guarantor (Bank)
Witness:	
1. _____	Signature _____
	Name _____
_____ Corporate Secretary (Seal)	Title _____
2. _____	

Name, Title & Address	Corporate Guarantor (Seal)

FORM OF CONTRACT AGREEMENT

THIS CONTRACT AGREEMENT (hereinafter called the “Agreement”) made on the _____ day of _____(month) 2022 between

_____ (hereafter called the “Employer”) of the one part and _____(hereafter called the “Contractor”) of the other part.

WHEREAS the Employer is desirous that certain Works, viz _____ should be executed by the Contractor and has accepted a Bid by the Contractor for the execution and completion of such Works and the remedying of any defects therein.

NOW this Agreement witnessed as follows:

1. In this Agreement words and expressions shall have the same meanings as are respectively assigned to them in the Conditions of Contract hereinafter referred to.
2. The following documents after incorporating addenda, if any, except those parts relating to Instructions to Bidders shall be deemed to form and be read and construed as part of this Agreement, viz:
 - (a) The Contract Agreement;
 - (b) The Letter of Acceptance;
 - (c) The completed Form of Bid;
 - (d) Special Stipulations (Appendix-A to Bid);
 - (e) The Particular Conditions of Contract – Part II;
 - (f) The General Conditions – Part I;
 - (g) The priced Bill of Quantities (Appendix-D to Bid);
 - (h) The completed Appendices to Bid (B, C, E to L);
 - (i) The Drawings;
 - (j) The Specifications.
 - (k) _____(any other)
3. In consideration of the payments to be made by the Employer to the Contractor as hereinafter mentioned, the Contractor hereby covenants with the Employer to execute and complete the Works and remedy defects therein in conformity and in all respects with the provisions of the Contract.
4. The Employer hereby covenants to pay the Contractor, in consideration of the execution and completion of the Works as per provisions of the Contract, the Contract Price or such other sum as may become payable under the provisions of the Contract at the times and in the manner prescribed by the Contract.

IN WITNESS WHEREOF the parties hereto have caused this Agreement to be executed on the day, month and year first before written in accordance with their respective laws.

Signature of the Contactor

(Seal)

Signature of Employer

(Seal)

Signed, Sealed and Delivered in the presence of:

Witness:

(Name, Title and Address)

Witness:

(Name, Title and Address)

BILL OF QUANTITIES

GRAND SUMMARY

“ESTABLISHMENT OF PLASMA COLLECTION & PROCESSING FACILITY FOR BBMF DIABAR AT OJHA CAMPUS, DUHS, KARACHI”

S. No	DESCRIPTION	Amount (Rs.)
1.	PLASMA COLLECTION & PROCESSING FACILITY FOR BBMF DIABAR	
	GRAND TOTAL AMOUNT RS.	
	BID SECURITY 2.5%	
<u>FIGURE IN WORDS:</u>		

COST OF SUMMARY

PLASMA COLLECTION / PROCESSING
FOR FACILITY FOR BBMF DIABAR

S. No	DESCRIPTION	Amount (Rs.)
A	CIVIL WORKS	
B	PLUMBING WORKS	
C	EXTERNAL DEVELOPMENT WORK AND OTHER MISCELLANEOUS WORKS	
D	CLEAN ROOM WORKS	
E	ELECTRICAL WORKS	
F	DATA / IT WORKS	
G	CCTV WORKS	
H	FIRE ALARM WORKS	
	TOTAL AMOUNT RS.	

ESTABLISHMENT OF PLASMA COLLECTION & PROCESSING
FACILITY FOR BBMF DIABAR
BILL OF QUANTITIES

Sr.#.	Description	Unit	Quantity	Rate (Rs.)	Amount (Rs.)
	(A) Civil Works				
1	<p>EXCAVATION AND BACKFILLING Excavation for foundations, plinth beams etc in any strata upto required depth from natural ground level, including back filling and compacting in 150mm thick layers, wherever required with all leads, lift with suitable excavated material. Excavated material suitable for use as back filling material shall be stockpiled, if required, within the site of work or as directed by Engineer in charge, this stockpile material shall be transported back to places required fill or back fill. Surplus material unsuitable for use as filling material shall be disposed off away from site by dumpers. (No extra payment will be made in this regard). Complete in all respect as per drawing, specifications and directed by Engineer – in – charge. (only the size of lean concrete will be calculate for payment).</p>	Cft	7,000		
2	<p>Stone soiling hand packed with surface leveled off to the correct section with hammer dressed stones (size 100-150 mm) and filling voids with crush ash under foundation, compacting with compactor etc. complete in all respects as per specifications provided and instruction given by the Engineer Incharge.</p>	Cft	1,072		
3	<p>TERMITE PROOFING Applying termite treatment by spraying solution of 0.5% dieldrin, Aldrin or approved equivalent as per specification to the following locations complete in all respects to the entire satisfaction of the Project Incharge. a) At all excavations, at all walls bottom of pits and trenches for footing, plinth beams for foundation. b) All area to receive sand fill solinq or slab. c) All rough wood work in entire project. Note: New toilets area 10'-0" x 10'-0" included in termite proofing scope of work</p>	L/S	Job		
4	<p>Providing and applying 1/8" thick hot bitumen minimum (1/8"thick) (Grade 80/100) over plinth beams</p>	Sft	850		
5	<p>Providing, mixing, depositing, curing and compacting using S.R. cement lean concrete under foundations, plinth beams etc, as shown on the drawings with clean local sand and crushed stone, graded as specified, including formwork where required etc., complete in all respects as per drawing, specifications and directed by Engineer-in-charge.</p>				
(i)	Lean Concrete 1:4:8 (1450 Psi)	Cft	1,247		
(ii)	Lean Concrete 1:3:6 (2250 Psi)	Cft	1,217		

ESTABLISHMENT OF PLASMA COLLECTION & PROCESSING
FACILITY FOR BBMF DIABAR
BILL OF QUANTITIES

Sr.#.	Description	Unit	Quantity	Rate (Rs.)	Amount (Rs.)
6	Providing, mixing, depositing, vibrating and curing, reinforced cement concrete , in sub-structure using crushing stone and sand to relevant B.S.S/ASTM specifications with minimum compressive Cylinder strength (f'c in ksi) at 28 days using Sulphate Resistance (S.R cement) as under including water tight shuttering fixing and removing etc., but excluding the cost of reinforcing steel. Complete in all respect at any depth and any level. Complete as per specifications, drawings and all to the approval of Engineer – in – charge.				
(i)	Footings (f' c = 3 ksi)	Cft	706		
(ii)	Short Columns (f' c = 4 ksi)	Cft	268		
(iii)	Plinth and tie beams (f' c = 3 ksi)	Cft	686		
7	STEEL REINFORCEMENTS. Supplying, cutting, bending, binding and fixing in position Ribbed Deformed Bars, confirming to ASTM A615-76a having minimum yield strength of 60,000 psi, including, wastage, unspecified laps, steel chairs, rolling margining, binding wire, etc., complete in all respect as per drawings, specifications and to all approval of the Engineer – in –charge. Complete upto any floor and any height. (Unspecified Overlaps pin and chairs etc not to be paid).	Tons	32.76		
8	Sand filling with off material (brought from outside source) in plinth depression and where ever required laid in 300mm layer well waters consolidated and compacted with mechanical roller compacter with all respect. (Note varies as per site)	Cft	4,919		
9	CONCRETE OF SUPER – STRUCTURE Providing , mixing, depositing, vibrating and curing , reinforced cement, concrete, in super-structure using crushing stone and sand to relevant B.S.S/ASTM specifications with minimum compressive Cylinder strength (f'c in ksi) as mentioned at 28 days using Ordinary Portland (O.P cement) as under including water tight shuttering fixing and removing etc., but excluding the cost of reinforcing steel. Complete in all respect at any depth and any level. Complete as per specifications, drawings and all to the approval of Engineer – in – charge.				
(i)	Columns, ground to roof (f' c = 4 ksi)	Cft	782		
(ii)	7" thick slab at First floor (f' c = 3 ksi)	Sft	1,700		
(iii)	5" thick roof slab (f' c = 3 ksi)-Toilets	Sft	300		
(iv)	RCC Beams at 1st floor (f' c = 3 ksi)	Cft	1,000		
(v)	8" thick roof slab (f' c = 3 ksi)	Sft	950		
(vi)	RCC Beams at roof (f' c = 3 ksi)	Cft	613		
(vii)	RCC flooring; 6" thick	Cft	800		

ESTABLISHMENT OF PLASMA COLLECTION & PROCESSING
FACILITY FOR BBMF DIABAR
BILL OF QUANTITIES

Sr.#.	Description	Unit	Quantity	Rate (Rs.)	Amount (Rs.)
ARCHITECTURE					
10	Provide and Lay machine made solid block (800 psi) masonry walls set in 1:6 cement sand mortar including curing complete with scaffolding at any height. As shown on drawing and details, complete in all respects as per instruction given by the Engineer Incharge.				
(i)	8" thick solid wall	Sft	385		
(ii)	6" thick solid wall	Sft	3,706		
(iii)	4" thick solid wall	Sft	248		
11	Provide and laying 1:2:4, 3" thick complete on all respect as per drawing - Roof finishing	Sft	2,024		
12	Provide and apply 15 mm thick plaster to internal ceiling, beams, wall and jambs surfaces in 1:6 cement sand mortar include cost of 200mm wide expanded lath metal as approved fixed with steel nail as per drawing and specifications. (Ht. upto 20'-0")	Sft	3,555		
13	Applying 12 mm thick external cement plaster in 1:4 cement sand mortar rough including all bends, recesses, corners, jambs, grooves pattas with additional thickness and provision of drip moulds, complete with hacking the reinforced concrete surfaces, filling back the chases, fixing G.I. expanded metal lath as per approved sample over chases, electrical PVC pipes and joints between brick and RCC masonry, curing complete at any height plaster as per drawings and specifications. (Note: wall height upto 20'-0")	Sft	4,150		
14	Interior Painting Matt finish paint wall and ceiling for interior surface including all base work i.e. rubbing the surface with bathy, primer, filling the voids with zink/chalk plaster of paris mixer, making smooth surface complete as per drawings	Sft	3,555		
15	External Painting P/Applying 3-coats of weather shield paint of superior quality i/c preparing base surface and filling etc complete in all respects as per directives of engineering in charge.	Sft	4,150		
(A. Civil Works) - Total Cost Rs.					

**ESTABLISHMENT OF PLASMA COLLECTION & PROCESSING
FACILITY FOR BBMF DIABAR
BILL OF QUANTITIES**

Sr.#.	Description	Unit	Quantity	Rate (Rs.)	Amount (Rs.)
	(B) Plumbing Works				
1	Providing & fixing English Commode with Seat cover including flushing cistern, tee stop cock etc. complete in all respects (Porta /Marachi or equivalent).	Nos	1		
2	Providing and fixing C.P Brass Fancy bib cock with crystal head 1/2" dia (Master / Sonex or equivalent).	Nos	3		
3	Providing and fixing C.P Brass Double bib cock with Muslim Shower 1/2" dia Master/Sonex or equivalent)	Nos	3		
4	Providing and fixing C.P Brass Concealed stop cock with crystal head 1/2" dia (Master/Sonex or equivalent)	Nos	5		
5	Providing and fixing basin mixture i/c waste pipe, bolt kit, floor waste jali complete in all respect	Nos	2		
6	Providing and fixing of floor waste jali (0'-6" x 0'-6")	Nos	2		
7	Providing & fixing of UPVC Pipe complete with all accessories as per directed by Engineer				
(i)	3" diameter	Rft	60		
(ii)	4" diameter	Rft	60		
(B. Plumbing Works) - Total Cost Rs.					

**ESTABLISHMENT OF PLASMA COLLECTION & PROCESSING
FACILITY FOR BBMF DIABAR
BILL OF QUANTITIES**

Sr.#.	Description	Unit	Quantity	Rate (Rs.)	Amount (Rs.)
	(C) External Development Work and Other Miscellaneous Works				
1	Dismantling of existing cement concrete plan flooring layer (1:2:4) and disposal of rubbish materials by mean of tractor trolley or dumper complete in all respects as per instruction given by the Engineer Incharge.	Cft	767		
2	Dismantling of existing tiles flooring / skirting i/c. C.C layer and disposal of rubbish materials by mean of tractor trolley or dumper complete in all respects as per instruction given by the Engineer Incharge.	Sft	2,267		
3	Removing/chipping damaged cement plaster from walls i/c removal rubbish materials from site of work by means of tractor trolley or dumper complete in all respects as per instruction given by the Engineer Incharge.	Sft	8,020		
4	Removing wooden door frame with shutter carefully and stacking at site i/c disposal of rubbish materials by mean of tractor trolley complete in all respects as per instruction given by the Engineer Incharge.				
(i)	Size 3'-0" x 7'-0"	Nos.	2		
(ii)	Size 6'-0" x 7'-0"	Nos.	3		
(iii)	Size 6'-0" x 7'-6"	Nos.	1		
5	Dismantling of existing block masonry 6" to 8" thick and disposal of rubbish materials by mean of tractor trolley or dumper complete in all respects as per instruction given by the Engineer Incharge.	Sft	3,415		
6	Removal of existing aluminum windows carefully and stacking at site complete in all respects as per instruction given by the Engineer Incharge.	Nos.	7		
7	Removal of existing false ceiling (gypsum 2'x2') i/c channel frame carefully and stacking at site i/c disposal of rubbish materials by mean of tractor trolley or dumper complete in all respects as per instruction given by the Engineer Incharge.	Sft	442		
8	Removal of existing concrete lab counter slab i/c counter walls, tiles, steel and disposal of rubbish materials by mean of tractor trolley or dumper complete in all respects as per instruction given by the Engineer Incharge.				
(a)	Size 17'-0" x 3'-0"	Nos.	1		
(b)	Size 30'-0" x 3'-0"	Nos.	2		
9	Dismantling/removal of existing precast slab, girders carefully and stacking at site i/c disposal of rubbish materials by mean of tractor trolley or dumper complete in all respects as per instruction given by the Engineer Incharge.	Sft	570		
10	Dismantling of existing MS corrugated roof sheet i/c MS frame, fiber sheet carefully and disposal of rubbish materials by mean of tractor trolley or dumper complete in all respects as per instruction given by the Engineer Incharge.	Sft	729		

ESTABLISHMENT OF PLASMA COLLECTION & PROCESSING
FACILITY FOR BBMF DIABAR
BILL OF QUANTITIES

Sr.#.	Description	Unit	Quantity	Rate (Rs.)	Amount (Rs.)
11	EXCAVATION AND BACKFILLING Excavation for foundations, plinth beams etc in any strata upto required depth from natural ground level, including back filling and compacting in 150mm thick layers, wherever required with all leads, lift with suitable excavated material. Excavated material suitable for use as back filling material shall be stockpiled, if required, within the site of work or as directed by Engineer in charge, this stockpile material shall be transported back to places required fill or back fill. Surplus material unsuitable for use as filling material shall be disposed off away from site by dumpers. (No extra payment will be made in this regard).	Cft	11,844		
12	Stone soiling hand packed with surface leveled off to the correct section with hammer dressed stones (size 100-150 mm) and filling voids with crush ash under foundation, compacting with compactor etc complete in all respects as per specifications provided and instruction given by the Engineer Incharge.	Cft	3,105		
13	Providing, mixing, depositing, curing and compacting using S.R. cement lean concrete under foundations, plinth beams etc, as shown on the drawings with clean local sand and crushed stone, graded as specified, including formwork where required etc., complete in all respects as per drawing, specifications and directed by Engineer-in-charge.				
(i)	Lean Concrete 1:4:8 (1450 Psi)	Cft	4,246		
(ii)	Lean Concrete 1:3:6 (2250 Psi)	Cft	330		
14	Sand filling with off material (brought from outside source) in plinth depression and where ever required laid in 300mm layer well wateres consolidated and compacted with mechanical roller compactor with all respect. (Note varies as per site)	Cft	6,921		
15	Provide and lay 3" thick cement concrete finish floor (1:2:4) , complete in all respects as per instruction given by the Engineer Incharge	Sft	8,250		
16	Provide and Lay machine made solid block (800 psi) masonry walls set in 1:6 cement sand mortar including curing complete with scaffolding at any height. As shown on drawing and details, complete in all respects as per instruction given by the Engineer Incharge.				
(i)	6" thick solid wall	Sft	2,407		
17	Supplying and installation of precast slab size 4'-0" x 2'-0" i/c girder size 4" x 9" carefully complete in all respect as per directives of engineering in charge.	Sft	324		
18	Provide, fabricate and fix hollow GI frame for doors , using pressed sheet metal of 16 gauge. Frame fabricated by continuous welding, glazing beads, reinforcement for hinge, lock and closer, installation on side frames to be filled with cement sand motor including anchoring, install door stops, finish with approved enamel paint 3 coats (ICI/Berger or approved equivalent) over primer after installations including CC 1:4 door sill 6"x1 " or 8"x1 " etc. complete in all respects as approved by Project Architect.				
(i)	Frame Size 2-1/2" x 7-1/2"	Rft	88		

ESTABLISHMENT OF PLASMA COLLECTION & PROCESSING
FACILITY FOR BBMF DIABAR
BILL OF QUANTITIES

Sr.#.	Description	Unit	Quantity	Rate (Rs.)	Amount (Rs.)
19	Provide and apply 15 mm thick plaster to internal/external beams, wall, jambs , bends, recesses, corners, grooves patta with additional thickness surfaces in 1:6 cement sand mortar include cost of 200mm wide expanded lath metal as approved fixed with steel nail as per drawing and specifications.	Sft	15,500		
20	Provide and make 1 3/4" thick solid core flush door with 2 1/2" Wide partal wood frame all round 6 x 1 1/4" partal wood mid rail in two pieces partal wood for lock fitting all shutter with 3/4" x 1" 1/4" x 10" partal wood pieces Formica finish over 1/8" thick ply in all respect as per drawing.	Sft	310		
21	Providing and fixing C.P Brass Mortice Lock with Long Handle (Heavy Design Imported Euro Made)	Nos.	18		
22	Interior Painting Matt finish paint wall and ceiling for interior surface including all base work i.e. rubbing the surface with bathy, primer, filling the voids with zink/chalk plaster of paris mixer, making smooth surface complete as per drawings	Sft	15,500		
23	External Painting P/Applying 3-coats of weather shield paint of superior quality i/c preparing base surface and filling etc complete in all respects as per directives of engineering in charge.	Sft	9,387		
24	Provide, fabricate and fix hollow metal frame for doors, using pressed sheet metal of 16 gauge. Frame fabricated by continuous welding, glazing beads, reinforcement for hinge, lock and closer, installation on side frames to be filled with cement sand motor including anchoring, install door stops, finish with approved enamel paint 3 coats (ICI/Berger or approved equivalent) over primer after installations including CC 1:4 door sill 6"x1 " or 8"x1 " etc. complete in all respects as approved by Proiect Architect.				
(i)	Frame Size 2-1/2" x 9-1/2"	Rft	19		
(ii)	Frame Size 2-1/2" x 5-1/2"	Rft	17		
25	Supply and fix MS doors made of steel 2mm thickness both sides as per specification and instructions of supervisor engineer. Price to include door frame of galvanized steel 2mm thickness, metallic painting of door and door frame, ironmongery, cylinders, and cylindrical locks and handles (as approved), Glass and glazing to be 6mm thick as directed by the engineer, including cutting to size, putty and rubber; door closure of good quality and all accessories as per Engineer instructions. (a) Size 6'-0" x 7'-0" (b) Size 4'-0" x 7'-0" (c) Size 3'-0" x 7'-0"	Sft	112		
26	Provide and lay Porcelain tile on floor made with 1:4 cement sand mortar bed and dry bond including grouting; complete in all respect as per drawings and specifications.				
(i)	Flooring 600 mm x 600 mm	Sft	1,164		
(ii)	Wall dado	Sft	875		

ESTABLISHMENT OF PLASMA COLLECTION & PROCESSING
FACILITY FOR BBMF DIABAR
BILL OF QUANTITIES

Sr.#.	Description	Unit	Quantity	Rate (Rs.)	Amount (Rs.)
27	Provide and lay Porcelain tile on floor made with 1:4 cement sand mortar bed and dry bond including grouting; complete in all respect as per drawings and specifications.				
(i)	Border/skirting 6" wide	Rft	187		
28	Provide and lay Ceramic tile on floor made with 1:4 cement sand mortar bed and dry bond including grouting; complete in all respect as per drawings and specifications.				
(i)	Flooring	Sft	394		
(ii)	Dado	Sft	965		
29	Providing and fixing false ceiling gypsum sheet 2'-0" x 2'-0" with galvanized Iron T-Channel framing suspension of with all respect etc complete.	Sft	1,236		
30	Enamel Paint on iron work P/Applying 3-coats of enamel paint of superior quality i/c preparing base surface and filling etc. on gated iron bar gratings, railing, grills complete in all respects as per directives of engineering in charge.	Sft	1,614		
31	Provide and install bronze section 1.2mm Aluminum anodized windows using approved section for frame glazed and wire mesh shutter with cost of light tinted glass, refer schedule given in drawing No for manufacturing and fitting details complete with cost of sealant etc. as required by Architect.	Sft	60		
32	S/F window printed blinds Shangrila (Horizontal/Vertical) with printed design & of approved colour i/c fixing in windows with necessary accessories etc. complete in all respects as per directives of Engineer In-charge.	Sft	91		
33	Supplying and fixing Steel grill of 1/2" x 1/2" vertical and horizontal square bar @ 6" c/c as per approved design i/c Painting 2 coats of oil paint with one coat red oxide paint etc: complete in all respects as per specifications and drawings and approval of Engineer In charge.	Sft	48		
34	Providing and fixing aluminum anodized fully glazed swing/sliding door made with heavy duty premium model aluminum section 4 inch wide and 2mm thick with collar along with 5mm thick tinted glass fixed with PVC gasket along with PVC handles of 5 inch wide and 1.6mm thick and all necessary hardware fittings, locking arrangement etc., complete in all respect	Sft	24		
35	Supply and installation heavy duty hydraulic door closer (JB saeed - series #: 82-brown door closer-55 kg Japan) complete in all respect	Nos.	21		
36	Supplying and laying cement concrete interlocking paver blocks of any design/ shape laid in required line, level, curvature, colour and pattern over and including 60 mm thick compacted bed of coarse sand, filling the joints with fine sand etc. all complete as per the direction of Engineer in-charge.	Sft	8,038		
37	Providing and fixing Precast Kerb Stones edge block 3750 PSI industrial made size 6 inch thick x 12 inches long x 18" inches high including the cost of cartage, excavation, form work for haunching, 1450 PSI lean concrete, 2250 PSI concrete for haunching, 1:4 cement sand mortar filling joint, two coats of enamel reflector paint etc. complete with all respect. Make: Envicrete, (Banu Mukhtar) Bincrete, Megnacrete, Izhar	Rft	600		

ESTABLISHMENT OF PLASMA COLLECTION & PROCESSING
FACILITY FOR BBMF DIABAR
BILL OF QUANTITIES

Sr.#.	Description	Unit	Quantity	Rate (Rs.)	Amount (Rs.)
38	Supplying and spreading gravel to approved quality from approved quarry in required 1.5" to 2.0" thickness to proper camber and grade.	Cft	3,021		
39	<p>Providing, supplying and applying epoxy flooring of (average 3mm thickness) on concrete flooring, including surface preparation, application of primer, screed and top coat etc. to have a neat and smooth finish that included;</p> <p>(a) Moisture Barrier:- After the floor preparation by grinding the floor for removal of unwanted extra pitting to provide the smooth floor and providing and applying, waterborne epoxy primer is applied with a brush or short / medium pile roller by ensuring a uniform coating is achieved and compensated the differences in surface porosity, allowing to dry for 24 Hrs., etc. and complete as per manufacturer's specification.</p> <p>(b) Primer:- After the moisture barrier completed & dried for further operation, solvent free epoxy primer base for epoxy flooring is applied with a brush or short / medium pile roller by ensuring a uniform coating is achieved and compensated the differences in surface porosity, allowing to dry for 24 Hrs. etc. and complete as per manufacturer's specification.</p> <p>(c) Epoxy screed:- Providing and installing, high performance, epoxy resin flooring system by mixing all 3 components using heavy duty slow speed drilling machine fixed with mixing paddle, pouring of mixed material on the primed surface and spreading it using suitable trowel / pin rake trowel at required thickness around 3 mm, gently rolling the spike roller to remove the entrapped air, etc. and complete as per manufacturer's specification.</p>	Sft	1,800		
40	Horizontal thrust boring under road cross manual 0'-0" to (- 2'-6" or 3'-0") for laying of 8" dia UPVC pipe at different locations mentioned in layout plan including cost of pipe complete in all respect.	Rft	50		
	<u>Sewerage line</u>				
41	Excavation for sewerage pipe tranches of soils, dry or wet, hard or soft, upto required depth including all operation of dewatering at site clearing and backfilling or filling the excavated material to specified depth to any lead within site., complete with breaking clods, leveling, dressing, watering and compacting.	Cft	6,300		
42	Earth filling from outsource in trench lay in 9" thick layer well watered, consolidated and compacted with plate compactor.	Cft	1,181.25		
43	Providing, laying and jointing UPVC sewer pipe, Dadex or AGM pipe of Class 'B' including excavation backfilling, compaction bedding, lowering in trenches to correct alignment and grade, jointing, cutting pipes where necessary, finishing and testing complete as per drawing and satisfaction to the engineer.				
(i)	200 mm Ø	Rft	188		
(ii)	250 mm Ø	Rft	859		

ESTABLISHMENT OF PLASMA COLLECTION & PROCESSING
FACILITY FOR BBMF DIABAR
BILL OF QUANTITIES

Sr.#.	Description	Unit	Quantity	Rate (Rs.)	Amount (Rs.)
44	Providing and fixing 225mm x 225mm uPVC Gully Trap with Frame and cover including uPVC gully trap chambers as per drawing complete in all respect.	Nos.	8		
45	Construction and making of fair-faced manhole for required size sewerage line with wall thickness (4" thick) RCC ratio 1:2:4, complete in all respect including excavation, backfilling, compaction, manhole cover (weight: 52kg) with frame complete as per drawing and satisfaction to the engineer, including testing. (Note: All material to be supplied by the contractor) For depth 2'-0" to 2'-6" (Size 450mm x 450mm)	Nos.	27		
(C. External Development Work and Other Miscellaneous Works) - Total Cost Rs.					

ESTABLISHMENT OF PLASMA COLLECTION & PROCESSING
FACILITY FOR BBMF DIABAR
BILL OF QUANTITIES

Sr.#.	Description	Unit	Quantity	Rate (Rs.)	Amount (Rs.)
	(D) Clean Room Works				
1	60mm thick Walkable Roof Panel				
1.1	Supply and installation of 60mm thick Clean rooms Panels for roof should be provided from 0.55mm thick Pre-painted sheets (AZ 150 Bluescope Australia) both side of the panels non-conductive including 5mm thick board and insulated with 55mm thick 120 kg/m3 Rockwool fire retardant rigid boards. All panels surrounded by 0.8mm thick G.I sheets metal frame to prevent dust accumulate. All panels provided with intermediate aluminum joints, extrusion cross Tee and aluminum main grid tee to meet the pharma clean room requirement. Hanging plate laps & spacer extrusion fixing of rod to suspended ceiling. Cutting of panels for ducting and any other opening for diffuser, lights shall be provided. Installation: Including transportation & consumable silicon, fully threaded G.I rods, turnbucker, screw, holes for diffuser light & ducting, complete with all respect as per contract agreement / specification, instruction of Engineer or Incharge.	Sft	1,500		
2	50mm thick wall Panel				
2.1	Supply and installation of 50mm thick Clean Room wall panels should be provided from 0.55mm thick sheets of Pre-painted (AZ 150 Bluescope Australia) both side of the panel Non-conductive including insulated with 50mm thick 120 kg/m3 Rockwool fire retardant rigid boards. All panels surrounded by 0.8mm thick G.I sheets metal frame to prevent dust accumulate. All panels provided with intermediate aluminium joints which will meet the international requirements. The room size and partition should be according to the architectural drawings provided by client. Cutting of panels for ducting and any other opening for diffuser shall be provided. Installation: Including transportation & consumable silicon, rawalbolt, turnbucker, screw, holes for diffuser light & ducting, complete with all respect as per contract agreement / specification, instruction of Engineer or Incharge.	Sft	3,900		
3	Supplying and installation U Channels				
3.1	All U Channels shall be fabricated from Galvanized /PPGI material of 0.5mm thick fixed with the help of Rawal Bolts by Fischer. Size of channel 50mm x 50mm x 50mm and all panels fixed directly into channels	Rft	600		
4	Supplying and installation Aluminium Connection profile and Coving				
4.1	Extruded aluminium profiles for wall and roof panels. Top and bottom coving at wall both side, vertical coving at "T" connection , vertical "L" radial corners, "U" shape to cover the on site cutting holes. 3 - way connector and floor coving end piece to door.	Rft	3,500		
4.2	Aluminium Coving & corners.	Nos.	250		

**ESTABLISHMENT OF PLASMA COLLECTION & PROCESSING
FACILITY FOR BBMF DIABAR
BILL OF QUANTITIES**

Sr.#.	Description	Unit	Quantity	Rate (Rs.)	Amount (Rs.)
5	Accessories				
5.1	Supplying and laying PVC conduit pipe 1" Dia; make Glaco or Equivalent	Rft	1,400		
5.2	Supplying and installation Corner Joints	Nos.	90		
6	Supplying and installation FireRated Doors				
	Door Thickness: 45mm Thick (Make to Order). Vision Panel: 300mm x 400mm Double Glazed Glass of 5mm + 5mm. Insulation: 50mm thick Density 120 kg/m ³ Rockwool Rigid Board. Lock & Hinges: Stainless steel lever handle and hinges imported. Door cladding: Single Leaf Doors with internal and external 1.5mm thick Galvanized sheet and door frame of 2mm thick. Paint: All Doors and Door frames will be Epoxy paint of Powder coated 20-25 micron. Optional Accessories: Speed adjustable door clousers with a variety of opening and finishes as per approved sample imported.				
6.1	Door : D1 : 3'-6" x 7'-0" ft	Nos.	1		
6.2	Door : D2 : 3'-0" x 7'-0" ft	Nos.	16		
	(D) Clean Room Work - Total Cost Rs.				

ESTABLISHMENT OF PLASMA COLLECTION & PROCESSING
FACILITY FOR BBMF DIABAR
BILL OF QUANTITIES

Sr.#.	Description	Unit	Quantity	Rate (Rs.)	Amount (Rs.)
	(E) Electrical work				
	Wiring/Wiring Accessories				
1	Wiring for light, fan or plug point with 1.5 sq.mm single core, PVC insulated wire copper conductor wire in 25" mm dia PVC conduct recessed in the wall column, roof etc, including 1 sq.mm single core PVC insulated wire as ECC as required				
(i)	(From Switch Board to Point)	Each	80		
(ii)	(From Point To Point)	Each	160		
2	Circuit wiring to switch board including any wiring from switch board to switch board with 2 x 2.5Sqmm + ECC 1 x 2.5 Sqmm 1 core PVC wires 25mm dia of PVC conduit exposed/concealed as shown drawing	Each	35		
3	Wiring of 20A Duplex Flat Pin Switch Socket unit from DB to first outlet with 2x6mm CU/PVC + ECC 1x4 sq mm wires in 25mm dia PVC conduit of exposed / concealed as shown on drawings. Complete in all respects.	Each	15		
4	Wiring of 13A switch unit from DB to power point with 2x4 sq mm cu/PVC + ECC 1x4 PVC wires in PVC conduit/channel exposed /concealed as shown drawing	Each	35		
5	Providing and installation of following sizes 16 / 18 SWG Perforated G.I Cable Tray & Ladder with 18 SWG G.I Cover as per details given in the drawings and specifications. Size:- 100 x 75 mm Cable Tray 18 SWG & Cover 18 SWG	Rft	100		
	Switches & Sockets				
6	Providing & fixing 10Amps polycarbonate flame retardant One way switch with fancy gang plate fixed on die fabricated powder coated metal board recessed in wall or column including connection as required (Clipsal/Orange/ABB or equivalent)				
(i)	Power Socket	Each	240		
(ii)	Industrial Socket (3-Phase)	Each	1		
(iii)	Industrial Socket (Single Phase)	Each	4		
(iv)	Four Switch Plate	Each	15		
(v)	Five switch plate	Each	15		
7	Providing, installation, testing, commissioning and termination of following size of CU/PVC/PVC & CU/XLPE/PVC Cables for lighting Distribution Board & power distribution board in already installed PVC conduit / Cable tray, digging, buried, Bricks and Sand including all accessories, Complete in all respect as shown on drawing/as per Engineer approved.				
(i)	4C-25 Sq.mm Cu./PVC/PVC + 1C-16 Sqmm PVC	Mtr	125		
(ii)	1core-70 Sq.mm Cu./PVC/PVC	Mtr	95		
(iii)	4C-150 Sq.mm Cu./PVC/PVC	Mtr	250		
(iv)	4C-70 sq.mm CU/PVC + 1c-35 sq mm PVC	Mtr	40		

ESTABLISHMENT OF PLASMA COLLECTION & PROCESSING
FACILITY FOR BBMF DIABAR
BILL OF QUANTITIES

Sr.#.	Description	Unit	Quantity	Rate (Rs.)	Amount (Rs.)
	Light Fixtures				
8	Providing and installation of following lighting fixtures complete with ballast, starter p.f.i capacitor, high quality Driver and specified lamps. (Subject to approval of Architect / Consultant) Note: Color temperature shall be finalized as per Architect's /Site Engineers approval.				
(i)	Surface Mounted Down Light Fixture with 18W LED, OSAKA/Phillips Color 4K CRI 80	Each	150		
(ii)	Search Light 100 Watt (Philips/Osaka or equivalent)	Each	10		
(iii)	Ceiling Recessed 45W LED Panel 600 x 600mm Fixture of Diffused Glass Color Temp 4000K CRI 90%	Each	45		
(iv)	Providing & Fixing basic batten, surface type, fitting complete with TLD 2x36W white day light lamp starter, electronic ballast as Philips Cat. (TMS015/136 L.E.D)	Each	15		
(v)	Providing & Fixing basic batten, surface type, fitting complete with TLD 1x36W white day light lamp starter, electronic ballast as Philips Cat. (TMS015/136 L.E.D)	Each	10		
9	Providing and fixing Earth set with Copper Rod 1" Dia buried in the ground at a depth of 65 feet or less if water comes out from the ground level (with salt and charcoal, or Earth chemical powder) etc.. Making the pit 65 feet deep by excavation of all type	Each	4		
10	Providing, installation, testing and commissioning of following LV Panels and Distribution Boards made with 14/16 SWG sheet steel housing (14 SWG for floor standing & 16 SWG for wall mounted) with approved color and having specified circuit breakers as shown on drawing. (Refer Single Line Diagram and Power Schematic) DRAWINGS ATTACHED. Note: 1) Cost of Intelligent Lighting Control Relay and Power Supply unit should be included in cost of Distribution Board. 2) Safety locking arrangement is required for main incoming circuit breakers of all distribution boards. 3) All the Panels should be front accessible and maintainable.				
(i)	LDB Ground Floor	Each	1		
(ii)	PDB Ground Floor	Each	1		
(iii)	DB HVAC - (as per HVAC drawing)	Each	1		
11	Supplying, installation, connection testing & commissioning of Sub Main Distribution Board (SMDB), double powder quoted Panel Color, in 16 SWG, should be factory assembled Ready complete controlled Wired/Standard Capacity of material, LED Indications, Digital Volt Meters, Digital Ampere Meters with CT's 1000/5, Neutral & Earth Copper Bus Bars & Complete as per Electric Drawing, should Be Original Schneider/Terasaki JAPAN made ACB & MCCB Breakers OR approved/ equivalent in all respect.	Nos	2		
	01x 400Amp ACB/MCCB (Adj)/ Breaker				
	03x 250Amp ACB/MCCB (Adj)/ Breaker				
(E) Electrical Works: Total Cost Rs.					

**ESTABLISHMENT OF PLASMA COLLECTION & PROCESSING
FACILITY FOR BBMF DIABAR
MANDATORY REQUIREMENT**

Sr.#.	Description	Remarks
	Data/IT work	
	MANDATORY TECHNICAL REQUIREMENTS FOR THE ITEMS OF LOT NO. 4 (NONCOMPLIANCE SHALL LEAD TO REJECTION OF BIDS)	
1	Must quote Installation, termination, commissioning, tagging, rack dressing & Fluke testing of CAT6 UTP nodes	
2	Must quote Installation, termination, commissioning, rack dressing, OTDR report & Tagging of Optical Fiber cable.	
3	Must provide Shop drawing of CAT 6 & Fiber path marking.	
4	All 12 Core Fiber Optic cables need to be laid in the conduit and spliced from Sero-DB till Animal House Network Room.	
5	Quantity of items may vary according to the new requirements that may emerge during the implementation phase of the project.	
6	Any additional items/quantities that are required to complete the desired job and functionality may be included by the vendor in their proposal.	
7	Vendor must have proven experience for handling, at least three, such projects in the recent times in Government, education, and health sector of repute.	

ESTABLISHMENT OF PLASMA COLLECTION & PROCESSING
FACILITY FOR BBMF DIABAR
BILL OF QUANTITIES

Sr.#.	Description	Unit	Quantity	Rate (Rs.)	Amount (Rs.)
	(F) Data/IT work				
1	Network Switch (Access) 48x10/100/1000Base-T Ethernet port, 4x 10G SFP+ Ports AC Power Supply POE+ Forwarding Performance 132 Mpps/ Higher Switching Capacity: 176Gbits/higher 3 Meter Power cord C13/14 Must have 3-Years Advanced Replacement Onsite Warranty	Nos	1		
2	SFP + dual stand (Single-mode) Must be compatible with Network Switches	Nos	4		
3	Wireless LAN Access Points Must support IEEE 802.11a/b/g/n/ac Standards Minimum 2x2 MIMO streams Minimum Concurrent Clients must be 256 supported Antenna Gain should be 4dBi or higher in both 2.4GHz & 5GHz Must have at least one Gigabit Ethernet RJ-45 POE/POE+ Interface Max Radio Transmit power should be 25dBm or higher Must have 3-Years Advanced Replacement Onsite Warranty for all equipment Compatible with DUHS existing WLAN Controller Mounting kits for all Hardware Vendor will be responsible for mounting of APs	Nos	6		
4	Branded Desktop Computers (Mini Tower) CPU Core i5, latest generation RAM: 16GB (8x2) CPU should be Quad Core Storage: 240GB SSD or higher No Operating System (Free DOS) Optical Mouse Black Wired Keyboard English Dual band wireless built-in plus BT 18.5" LED Monitor 3 Years onsite warranty 1Gbps RJ-45 NIC	Nos	10		

ESTABLISHMENT OF PLASMA COLLECTION & PROCESSING
FACILITY FOR BBMF DIABAR
BILL OF QUANTITIES

Sr.#.	Description	Unit	Quantity	Rate (Rs.)	Amount (Rs.)
5	<p>Laser Printer (Network) Minimum Print speed of Up to 40 Pages Per Minute Resolution must be 1200 x 1200 dpi or higher Minimum Processor Speed required 1200 MHz Must have at least one Hi-Speed USB 2.0; Must have at least one host USB port Must have at least one Ethernet 10/100/1000BASE-T network Port Must have SNMP Network Monitoring Feature Minimum 256MB internal device memory Must Support Automatic Duplex Printing Must provide Printer Cable for direct PC Connectivity Must provide Power cord Flat 3-Pin UK-Type Plug Must Support Media Size: A4; A5; A6; B5 (JIS); B6 (JIS); 16K (195 x 270 mm, 184 x 260 mm, 197 x 273 mm); 10 x 15 cm; Oficio (216 x 340 mm); postcard (JIS single, JIS double); envelope (DL, C5, B5) Must Support Media Type: Paper (plain, Eco-EFFICIENT, light, heavy, bond, colored, letterhead, preprinted, pre-punched, recycled, rough); envelopes; labels</p>	Nos	5		
6	<p>Laser Printer (Color) Minimum Print speed of Up to 20 Pages Per Minute Resolution must be 600 x 600 dpi or higher Minimum Processor Speed required 1200 MHz Must have at least one Hi-Speed USB 2.0; Must have at least 1GB memory Must have at least one Ethernet RJ-45 network Port Must Support Automatic Duplex Printing Must provide Printer Cable for direct PC Connectivity Must provide Power cord Flat 3-Pin UK-Type Plug</p>	Nos	1		
7	<p>Biometric ID Machines Biometric machine with Camera/ IP Fingerprint plus card reader Network based POE/POE+ power (no injectors/ DC adapters) Quoted Devices must be compatible with existing DUHS Attendance System.</p>	Nos	2		
8	<p>UPS for ICT Equipment Output power capacity 3.0kVA Rack mount Battery Backup Output Connections (Minimum): 2 x C19 & 6 x C13 Nominal Output Voltage 230V Nominal Input Voltage 230V Input Connections: 3 Pin Flat Network Manageable via RJ-45 10/100/1000 Base-T Automatic internal bypass Audible and visible alarms prioritized by severity. Emergency Power Off (EPO) Rack mounting brackets battery bank to support 30 minutes backup time on full load 3 years principal warranty and onsite support.</p>	Nos	1		

ESTABLISHMENT OF PLASMA COLLECTION & PROCESSING
FACILITY FOR BBMF DIABAR
BILL OF QUANTITIES

Sr.#.	Description	Unit	Quantity	Rate (Rs.)	Amount (Rs.)
9	LAN and WLAN Nodes Cabling 48 x Company fabricated, 1Meter Cat6 patch cord 48 x Company fabricated, 3Meter Cat6 patch cord 02 x Patch Panel 24 ports loaded (Clipsal, Schneider, 3M) or Equivalent 6000 ft x Cat-6 UTP Network cable from access rack to user node (Vivanco/Dlink/Contech/Equivalent) 24 x Single Shutter Face Plate (Clipsal, Schneider, 3M) or Equivalent 10 x Dual Shutter Face Plate (Clipsal, Schneider, 3M) or Equivalent 44 x tool less I/O Jack (AMP, Clipsal, Schneider, 3M) or Equivalent 34 x Back Box MS Powder Coated, Compatible with Above face plate and compliant to industry standards, Installation, complete from all aspects 02 x Cable Manager Standard Quality PVC Material (Clipsal, Schneider, 3M) or Equivalent 01 Box x RJ-45 connector Network cabling including labor for ducting, Ethernet cabling, cable punching, I/O fixing, connector punching, etc. (1 Job) 200 ft x Cable Tray for Data Nodes (above ceiling installation) In this work all the network accessories must be included from User Nodes to network room rack (including pvc conducting)	JOB	ONE		
10	12 Core OFC (Armored Optical Fiber Cable) Fiber Optic Cable Laying & Termination with Testing Civil Work for Creation of Optical Fiber Route, with proper ducts & conduit	Mtr.	400		
11	Optical Fiber Splicing (24 core)	Nos	24		
12	Single mode (single core) Fiber Patch Cord (SC to SC): 1 Meter	Nos	12		
13	Single mode duplex Fiber Patch Cord (SC to LC): 3 Meter	Nos	6		
14	12-Ports Rack mount ODF: Loaded with SC Connectors	Nos	1		
15	Floor standing 42U Server Rack: with side arms cable manger (800 x 800)	Nos	1		
16	Rack mount PDU (8-Port): Input C-19, Output C-13	Nos	1		
17	Halotron type Manual fire extinguisher: capacity of 06 kgs with Hanging Bracket	Nos	1		
18	Normal SIP phones 1x 1G LAN Port 1x1G PC Port PoE at least 1 SIP account DSCP (L3 QoS) DHCP IPv4/IPv6 Supported Warranty Support for 3 years	Nos	12		
(F) Data/IT work: Total Cost Rs.					

ESTABLISHMENT OF PLASMA COLLECTION & PROCESSING
FACILITY FOR BBMF DIABAR
BILL OF QUANTITIES

Sr.#.	Description	Unit	Quantity	Rate (Rs.)	Amount (Rs.)
	(G) CCTV Work				
1	Providing & Installation of 32-Channel Network Video Recorder 1.5U 4HDDs 4K & H.265 Pro Network Video Recorder *16/32/64-channel IP video access Smart H.265+/Smart * H.264+/H.265/H.264/MJPEG; H.265 auto switch * Max 320 Mbps incoming bandwidth * Up to 24MP resolution for live view and playback * 1-channel fisheye dewarping (AI by NVR) * AI by Camera: Perimeter protection; face detection and recognition; SMD Plus; video metadata; ANPR; people counting; stereo analysis; crowd distribution; heat map	Nos.	1		
2	Providing & Installation of IR Fixed-focal lens Bullet Network Camera * 1/2.7" CMOS image sensor, low illuminance, high image definition * Outputs max. 4MP (2688 × 1520) @20 fps * H.265 codec, high compression rate, ultra-low bit rate * Built-in IR LED, max IR distance: 80 m * ROI, SMART H.264+/H.265+, flexible coding, applicable to various bandwidth and storage environments * Rotation mode, WDR, 3D NR, HLC, BLC, digital watermarking, applicable to various monitoring scenes * Intelligent detection: Intrusion, tripwire * Abnormality detection: Motion detection, video tampering, no SD card, SD card full, SD card error, network disconnection, IP conflict, illegal access, local alarm, voltage detection, audio detection * Alarm: 1 in, 1 out; audio: 1 in, 1 out; supports max. 256 GB Micro SD card * 12V DC/POE power support supply * IP67 protection, IK10 protection (optional)	Nos.	11		
3	Providing & Installation of IR Fixed-focal lens Dome Network Camera * 1/2.7" CMOS image sensor, low illuminance, high image definition * Outputs max. 4MP (2560 × 1440) @25/30 fps * H.265 codec, high compression rate, ultra-low bit rate * Built-in IR LED, max IR distance: 30 m * ROI, SMART H.264+/H.265+, flexible coding, applicable to various bandwidth and storage environments * Rotation mode, WDR, 3D NR, HLC, BLC, digital watermarking, applicable to various monitoring scenes * Intelligent detection: Intrusion, tripwire * Abnormality detection: Motion detection, video tampering, no SD card, SD card full, SD card error, network disconnection, IP conflict, illegal access, voltage detection * Supports max. 256 GB Micro SD card * 12V DC/PoE power supply * IP67, IK10 protection	Nos.	6		

ESTABLISHMENT OF PLASMA COLLECTION & PROCESSING
FACILITY FOR BBMF DIABAR
BILL OF QUANTITIES

Sr.#.	Description	Unit	Quantity	Rate (Rs.)	Amount (Rs.)
4	Providing & Installation of Surveillance Hard Drive Capacity 6TB Designed for 24/7 Surveillance-optimized Hard Drive Applications Engineered for Workloads up to 180 TB/year Capacity Up to 10 TB, Supports 32 Cameras per Drive Low Power Consumption and Startup Current Tarnish-resistant Components to Minimize Environmental Effects	Nos.	1		
5	Providing & Installation of 24-Port PoE Switch with (Gigabit) 2-SFP Port Supported * The parameters and datasheets below can only be applied to V2.0 & V3.0 * Intelligent PoE * Red port supports 90W IEEE802.3bt * Web management with friendly interface and easy operation * 250 m long distance PoE transmission * PoE watchdog * Plug and play	Nos.	1		
6	Providing & Installation of Branded/Imported 15-U Rack with Exhaust Fans & PDU	Nos.	1		
7	Providing & Installation of Water Proof Box Standard IP 67 Approved Quality	Nos.	11		
8	Providing & Installation of 1U 24- Port Patch Panel Fully Loaded	Nos.	1		
9	Providing & Installation of Cable Manager	Nos.	1		
10	Providing & Installation of 1 Meter Flexible Patch Cord 23 Awg Copper Insulation UTP	Nos.	18		
11	Providing & Laying of Cat-6 UTP Cable 23-Awg Copper	Rft	4000		
12	Providing & Laying of Fiber Optical Cable 12 Core	Meter	300		
13	Splicing of Fiber Optical Cable with testing & OTDR report	Core	16		
14	Providing & Installation of 4/8 Port ODF with Complete Accessories	Nos.	2		
15	Providing & Installation of 1-G Single Mode SFP SC Module, 1000Base-LX/LH Fiber Transceiver	Pair	1		
16	Providing & Installation of SC to SC Single-Mode Duplex Fiber Patch Cord 3 Meter	Nos.	2		
17	Harnessing of Fully Loaded Patch Panel, Management of Rack with all Cabling & Switching Accessories & Configuration of System by Assigning Static IP's , Orientation/Calibration of Camera's with fully satisfaction for concern department with All Respective	Nos.	1		
(G) CCTV Work - Total Cost Rs.					

ESTABLISHMENT OF PLASMA COLLECTION & PROCESSING
FACILITY FOR BBMF DIABAR
BILL OF QUANTITIES

Sr.#.	Description	Unit	Quantity	Rate (Rs.)	Amount (Rs.)
	(H) FIRE ALARM WORK				
1a	SUPPLY & INSTALLATION of 1-Loop Standalone Addressable FACP with 4.3" Color Touchscreen Display with total 100-device capacity. Approvals: UL, ULC Listed and FM Approved Simplex-Tyco Fire Protection Products, Johnson Controls, USA	NO.	1		
1b	SUPPLY & INSTALLATION of Dry Rechargeable Battery 12V 18Ah MAINTENANCE FREE, LEAD ACID, GELL TYPE Powersonic, USA	Nos.	2		
2	Installation, Programming, Commissioning & Testing of complete system	Job	1		
3	SUPPLY & INSTALLATION of Addressable Photoelectric Smoke Detector Addressable Smoke Detector which provides seven levels of sensitivity from 0.2% to 3.7% with 2 wire Base having inbuilt remote LED provision. Features: <ul style="list-style-type: none"> • UL listed to Standard 268 • Louvered smoke sensor design enhances smoke capture by directing flow to chamber; entrance areas are minimally visible when ceiling mounted • Designed for EMI compatibility • Magnetic test feature is provided • Optional accessories include remote LED alarm indicator and output relays Specifications: Operating Temperature Range: 15° to 122° F (-9° to 50° C) Humidity Range: 10 to 95% RH Approvals: UL, ULC, CSFM Listed; FM Approved; MEA (NYC) Acceptance Simplex-Tyco Fire Protection Products, Johnson Controls, USA	Nos.	20		
4	SUPPLY & INSTALLATION of Addressable Manual Double Action Push Pull Station-Break Glass Type with Metal Back Box Specifications: Temperature Range: 32° To 120° F (0° To 49° C) Intended For Indoor Operation Humidity Range: Up To 93% RH At 100° F (38° F) Housing Color: Red With White Raised Lettering Pull Lever: Color White With Red Raised Lettering Approvals: (UL, ULC LISTED & FM APPROVED) Simplex, TYCO Fire Protection Products, Johnsons Controls, USA	Nos.	5		
5	SUPPLY & INSTALLATION of Intelligent Addressable Horn cum Multi-Candela strobe Unit Intelligent Addressable Horn cum Multi-Candela strobe Unit, Customization of intensity selection from 15cd to 185cd of strobe with self-test diagnostic feature, which is able to generate NAC, pass / fail report. Approvals: UL, ULC, CSFM Listed; FM Approved; MEA (NYC) Acceptance Simplex-Tyco Fire Protection Products, Johnson Controls, USA	Nos.	5		

ESTABLISHMENT OF PLASMA COLLECTION & PROCESSING
FACILITY FOR BBMF DIABAR
BILL OF QUANTITIES

Sr.#.	Description	Unit	Quantity	Rate (Rs.)	Amount (Rs.)
6	SUPPLY & INSTALLATION of Dual port, bi-directional communications fault isolator for Detector loop circuit Approvals: UL, ULC, CSFM Listed; FM Approved; MEA (NYC) Acceptance Simplex-Tyco Fire Protection Products, Johnson Controls, USA	Nos.	2		
7	SUPPLY & INSTALLATION of Dry Chemical Powder Fire Extinguisher 06-Kg Capacity, (±10%) C/W Wall Bracket, Pressure Gauge and Initial Charge, EN3 Approved 'Gloria' Germany	Nos.	16		
8	SUPPLY & INSTALLATION of Carbon Dioxide 05-kg ALLOY STEEL body Fire Extinguisher with wall bracket C/W wall bracket and initial charge DN EN3 approved BS version 'Gloria' Europe	Nos.	17		
9	Installation material including 1.5 mm ² FR Cable, PVC Pipe, Fittings & Accessories as per drawing	Job	1		
(H) FIRE ALARM Work - Total Cost Rs.					

**TENDER DRAWINGS OF
“ESTABLISHMENT OF PLASMA COLLECTION &
PROCESSING FACILITY FOR BBMF DIABAR”**

PLASMA COLLECTION & PROCESSING LABORATORY

Dow University of Health Sciences, Osha Campus, Karachi



 DOW UNIVERSITY OF HEALTH SCIENCES
PLASMA COLLECTION & PROCESSING LABORATORY
1. Introduction
2. Objectives
3. Scope
4. Justification
5. Location
6. Site Plan
7. Architectural Plan
8. Equipment List
9. Staffing
10. Budget
11. Conclusion
12. References
13. Appendix
14. Glossary
15. Index

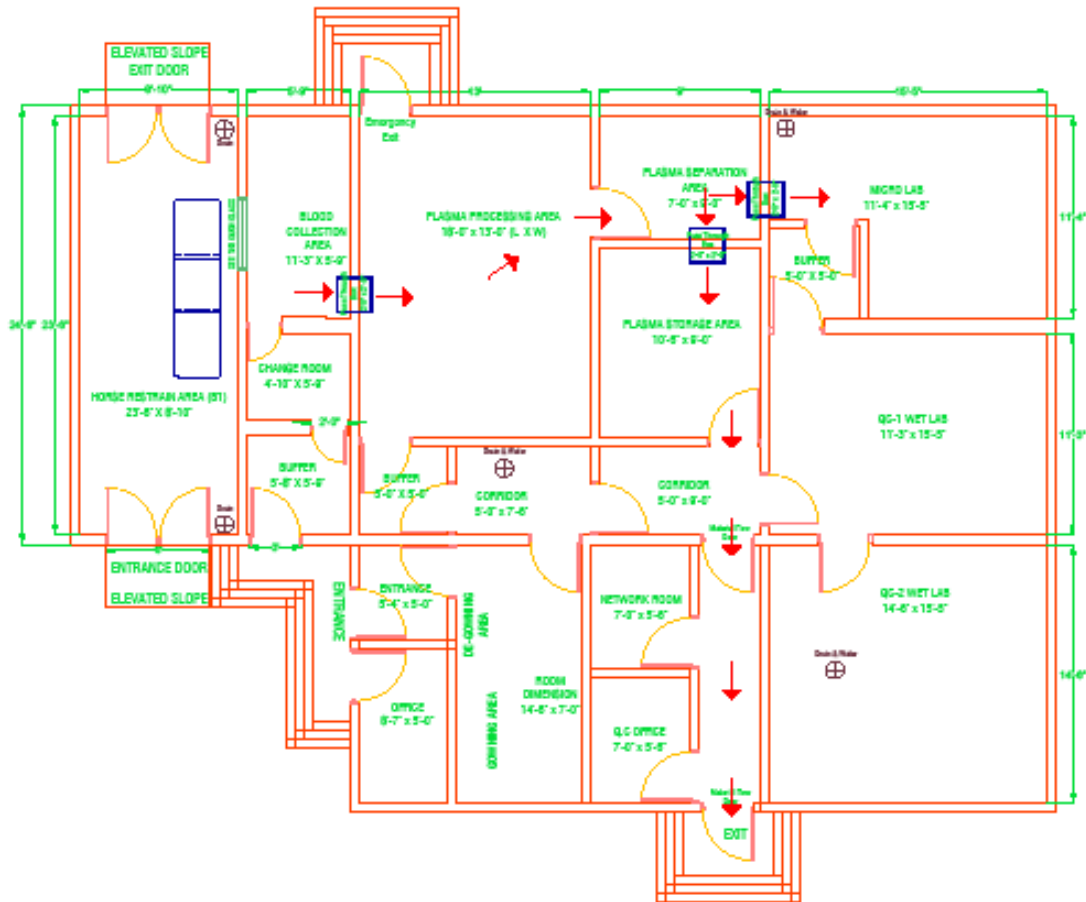

PLASMA COLLECTION AND PROCESSING LABORATORY
MATERIAL FLOW

 UNIVERSITY OF MISSISSIPPI	
PLASMA COLLECTION AND PROCESSING LABORATORY	
1. GENERAL NOTES: 2. ALL WORK SHALL BE IN ACCORDANCE WITH THE LATEST EDITIONS OF THE INTERNATIONAL CODES AND STANDARDS. 3. ALL MATERIALS AND EQUIPMENT SHALL BE APPROVED BY THE ARCHITECT. 4. ALL WORK SHALL BE COMPLETED WITHIN THE SPECIFIED TIME FRAME.	
PROJECT NO: BT-PG-103	SHEET NO: 00

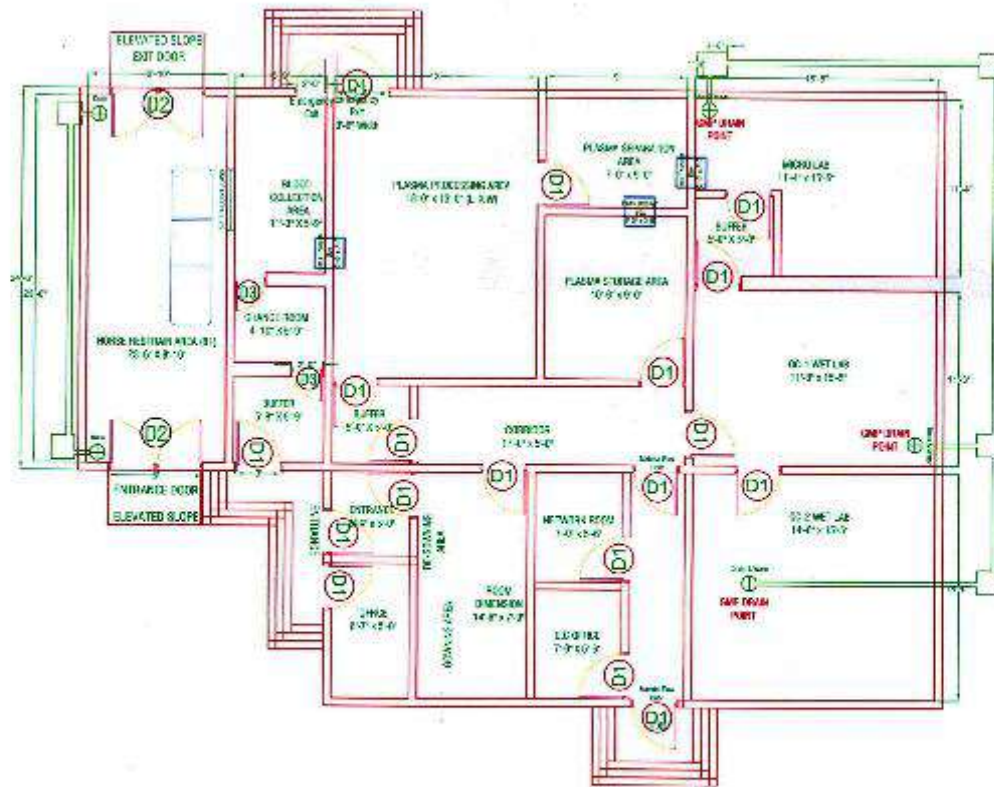

PLASMA COLLECTION AND PROCESSING LABORATORY
WATER & DRAIN POINTS LAYOUT



**THE UNIVERSITY OF
WEST INDIES**

**PLASMA COLLECTION AND
PROCESSING LABORATORY**

WATER & DRAIN POINTS LAYOUT

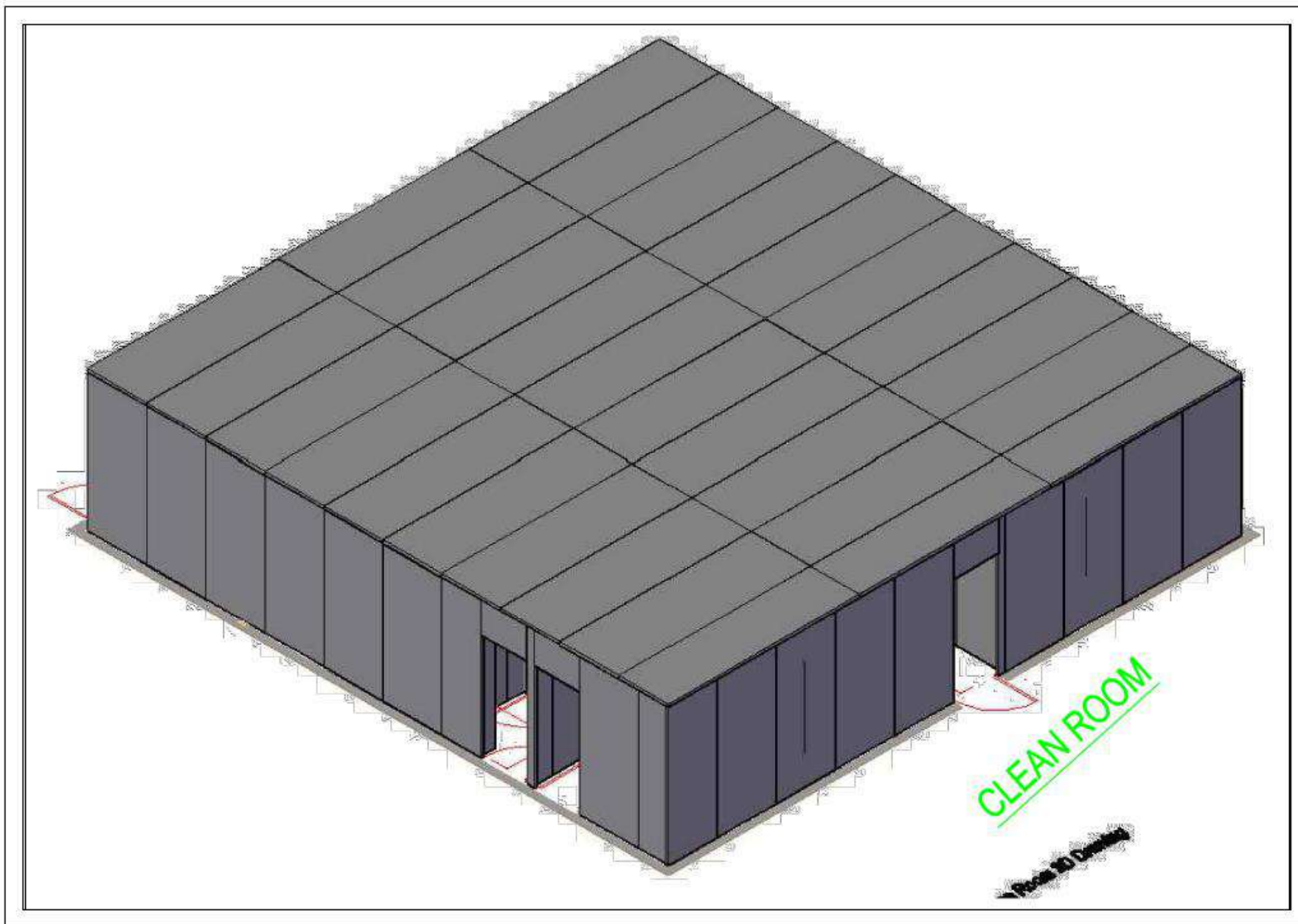
WUP2-001 00

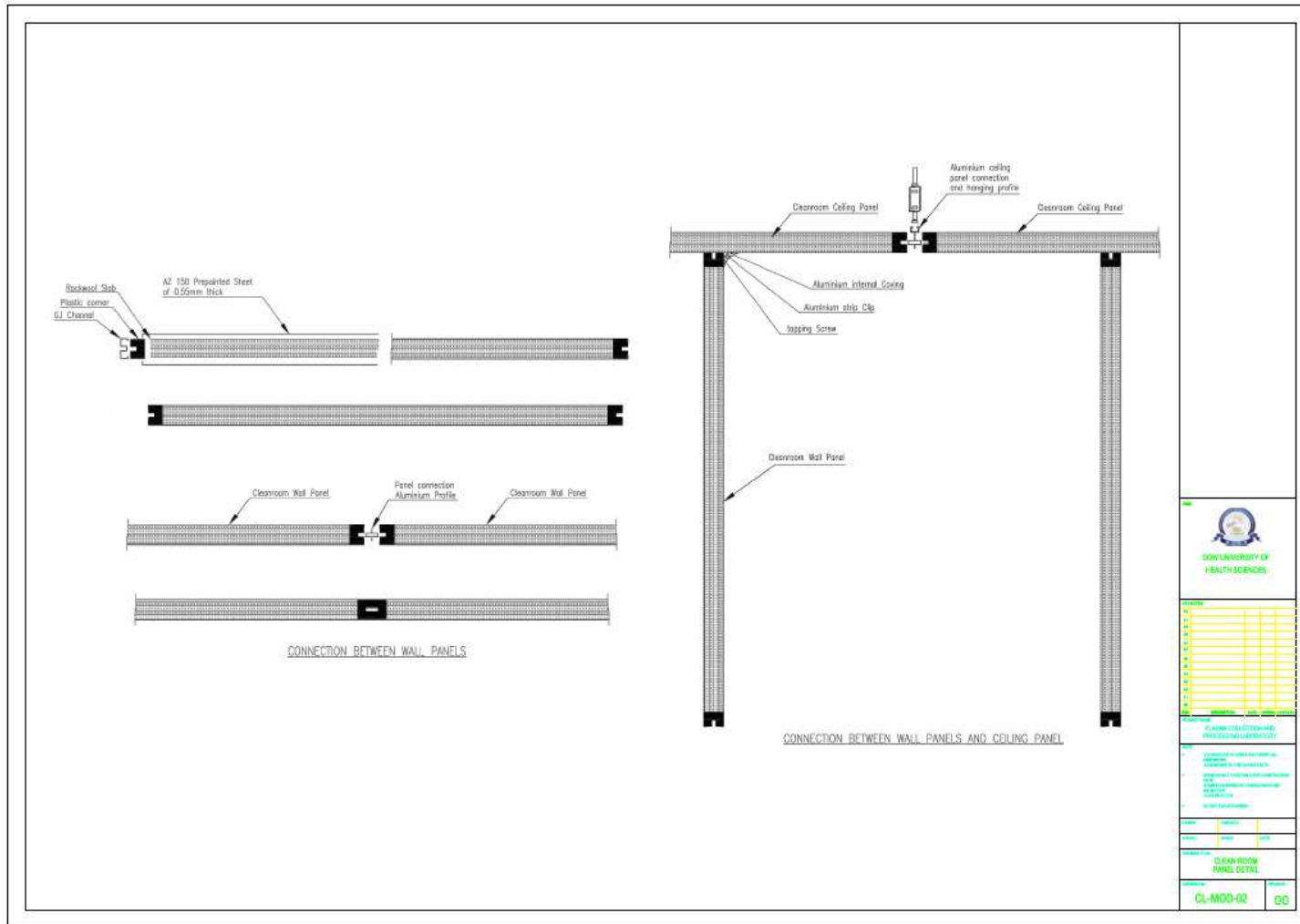



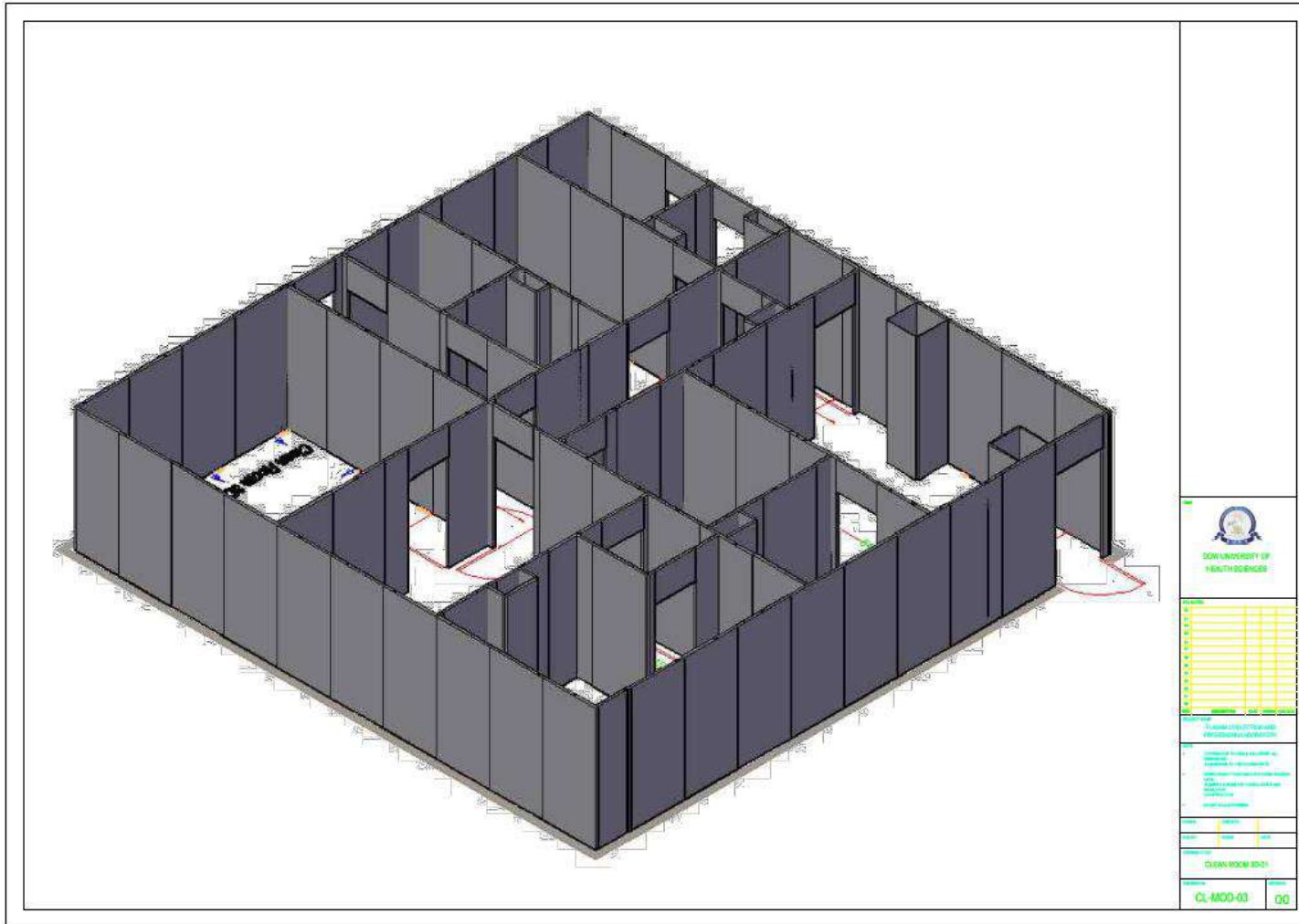



Daily AWAMI AWAZ



**OFFICE OF THE DIRECTOR PLANNING & DEVELOPMENT
DOW UNIVERSITY OF HEALTH SCIENCES**

Bahra-e-Urdu Road, Karachi-74200 Pakistan. Street No. 52-21-9921600/Fac: 99216045
Tel: 9215754 37 Ext: 3147/Website: www.duhs.edu.pk, E-mail: planning@duhs.edu.pk

Ref No: DUHS/P&D/2023/11318 Dated: 07 January, 2023

تصحيح - II

بحوالو ٽينڊر گھراڻن جو نوٽيس (اين آءِ سي) نمبر /DUHS/ P&D/2022/11300 بتاريخ 26 ڊسمبر 2022 جيڪو روزاني دان، روزاني جنگ ۽ روزاني عوامي آواز پر 28 ڊسمبر 2022 تي شايع ٿيو هو ۽ ڊائيوينيورسٽي آف هيلٿ سائنسز (ڊي يو ايج ايس) ۽ سنڌ پبلڪ پروڪيورمينٽ ريگوليٽري اٿارٽي (ايس پي ايس) جي ويب سائيٽس تي بحوالو PPMS ID No. T00573-22-0011 اپ لوڊ ٿيو هو

ESTABLISHMENT OF PLASMA COLLECTION & PROCESSING FACILITY FOR BBMF DIABAR AT OJHA CAMPUS, DUHS, KARACHI.

(REFNO: DUHS/W&S-NIT/104)

اڳاڻو ٿو ڪجي ته واک جي دستاويزن ۾ ترميم/اصلاح/منا سٿا ڪئي وئي آهي. مڙني دلچسپي رکندڙ اهل واک ڏيندڙن کي درخواست ٿي ڪجي ته اهي پنهنجي واک کي ترميم ڪيل/اصلاح ڪيل/منا سٿا ڪيل واک جي مطابق مڪمل ڪن.

چيئر مين پروڪيور مينٽ ڪاميٽي
ڊائيوينيورسٽي آف هيلٿ سائنسز

جمعرات 19 جمادی الثانی 1444ھ 12 جنوری 2023ء

www.jang.com.pk

f JangDotComDotPk @ jangdotcom jang_akhbar

پاکستان کے سرفراز نامہ سہ ماہیہ باقاعدہ تصدیق شدہ اشاعت ABC CERTIFIED

THE DAILY JANG KARACHI

دور رس

جنگ سرگرمی

بانی: میر خلیل الرحمن

ج 87

جمعرات 19 جمادی الثانی 1444ھ 12 جنوری 2023ء

نمبر 12

THURSDAY JANUARY 12, 2023



OFFICE OF THE DIRECTOR PLANNING & DEVELOPMENT
DOW UNIVERSITY OF HEALTH SCIENCES

Baba-e-Urdu Road, Karachi-74200 Pakistan, Direct No. 92-21-99216045/Fac: 99216045
Tel: 9215754-57 Ext: 5147/Website: www.dohs.edu.pk, E-mail: pccoffar.ah@hah@dohs.edu.pk

Ref No: DUHS/P&D/2023/11318

Dated: 07 January, 2023

تصحیح - II

بحوالہ نوٹس طلبی ٹینڈر (این آئی ٹی) نمبر DUHS/P&D/2022/11300
مورخہ 26 دسمبر 2022 جو روز نامہ ڈان، روز نامہ جنگ اور روز نامہ عوامی آواز
میں 28 دسمبر 2022 کو شائع ہوا تھا اور ڈاؤن لوڈ نیورٹی آف ہیلتھ سائنسز (ڈی ایچ ایچ
ایس) اور سندھ پبلک پروکیورمنٹ ریگولیشنز اتھارٹی (ایس پی پی آر اے) کی
ویب سائٹس پر بحوالہ PPMS ID No. T00573-22-0011۔

ESTABLISHMENT OF PLASMA COLLECTION &
PROCESSING FACILITY FOR BBMF DIABAR AT OJHA
CAMPUS, DUHS, KARACHI.

(REFNO: DUHS/W&S-NIT/104)

مطلع کیا جاتا ہے کہ پیشکش کی دستاویزات میں ترمیم/اصلاح اردو بدل کر دیا گیا
ہے۔ تمام دلچسپی رکھنے والے اہل بولی دہندگان سے درخواست کی جاتی ہے کہ وہ اپنی
پیشکش کو ترمیم شدہ/اصلاح شدہ/تبدیل شدہ پیشکش کے مطابق مکمل کریں۔

چینر مین پروکیورمنٹ کمیٹی

ڈاؤن لوڈ نیورٹی آف ہیلتھ سائنسز



FOUNDED BY QUAID-I-AZAM MOHAMMAD ALI JINNAH



Thursday
January 12, 2023
Jumad-us-Sani 19, 1444
KARACHI
Rs 30.00
18 Pages
Vol. LXXVII No. 12
Regd. No. 55-022
www.dawn.com



**OFFICE OF THE DIRECTOR PLANNING & DEVELOPMENT
DOW UNIVERSITY OF HEALTH SCIENCES**

Baba-e-Urdu Road, Karachi-74200 Pakistan. Direct No. 92-21-99216065 Fax: 99216065
Tel: 9215754-57 Ext: 5147 Website: www.duhs.edu.pk, E-mail: muzaffar.alishah@duhs.edu.pk

Ref No: DUHS/P&D/2023/11330

Dated: January 10, 2023

CORRIGENDUM-II

Reference to the Notice Inviting Tender (NIT) No. **DUHS/P&D/2022/11300**, Dated: **26th December, 2022** appeared in Daily Dawn, Daily Jang and Daily Awami Awaz as on 28th December, 2022 and uploaded on Dow University of Health Sciences (DUHS) and Sindh Public Procurement Regulatory Authority (SPPRA) website at PPMS ID No. T00573-22-0011.

ESTABLISHMENT OF PLASMA COLLECTION & PROCESSING FACILITY FOR BBMF DIABAR AT OJHA CAMPUS, DUHS, KARACHI.

(REF NO: DUHS/W&S-NIT/104)

The bidding document has been amended / corrected / modified. All the interested eligible bidders are requested to please furnish their bid in accordance with the amended / corrected / modified bid.

All others terms and condition will remain the same.

CHAIRMAN PROCUREMENT COMMITTEE
Dow University of Health Sciences, Karachi



OFFICE OF THE DIRECTOR WORKS & SERVICES
DOW UNIVERSITY OF HEALTH SCIENCES

Baba-e-Urdu Road, Karachi-74200 Pakistan. Direct No. 92-21-99216065 Fax: 99216065
Tel: 9215754-57 Ext: 5814 Website: www.duhs.edu.pk

Ref No: DUHS/W&S/2023/900

Dated: January 10, 2023

CORRIGENDUM

Reference to the Notice Inviting Tender (NIT) No. **DUHS/P&D/2022/11300**, Dated: **26th December, 2022** appeared in Daily Dawn, Daily Jang and Daily Awami Awaz as on 28th December, 2022 and uploaded on Dow University of Health Sciences (DUHS) and Sindh Public Procurement Regulatory Authority (SPPRA) website at PPMS ID No. T00573-22-0011 for the **ESTABLISHMENT OF PLASMA COLLECTION & PROCESSING FACILITY FOR BBMF DIABAR AT OJHA CAMPUS, DUHS, KARACHI. (REF NO: DUHS/W&S-NIT/104).**

Following changes have been made in the above-referred tender:

1. Light Fixtures (Item No: 10 & 11, Page No: 64) and Fire Alarm Work (Item No: 9, Page No: 72), Single Line Diagram and Power Schematic, drawings have been added.
2. (F) Data/IT work (Item No: 09, Page No: 68) consider this item as one job.

The above modified Clauses may be downloaded from Dow University of Health Sciences (DUHS) and Sindh Public Procurement Regulatory Authority (SPPRA) website at PPMS NIT ID No. T00573-22-0011

NOTE:

- a. Interested bidders are requested to note the aforementioned corrections / modifications / changes for strict compliance.
- b. All other terms and conditions of the tender shall remain unchanged.

DIRECTOR
Works & Services Department

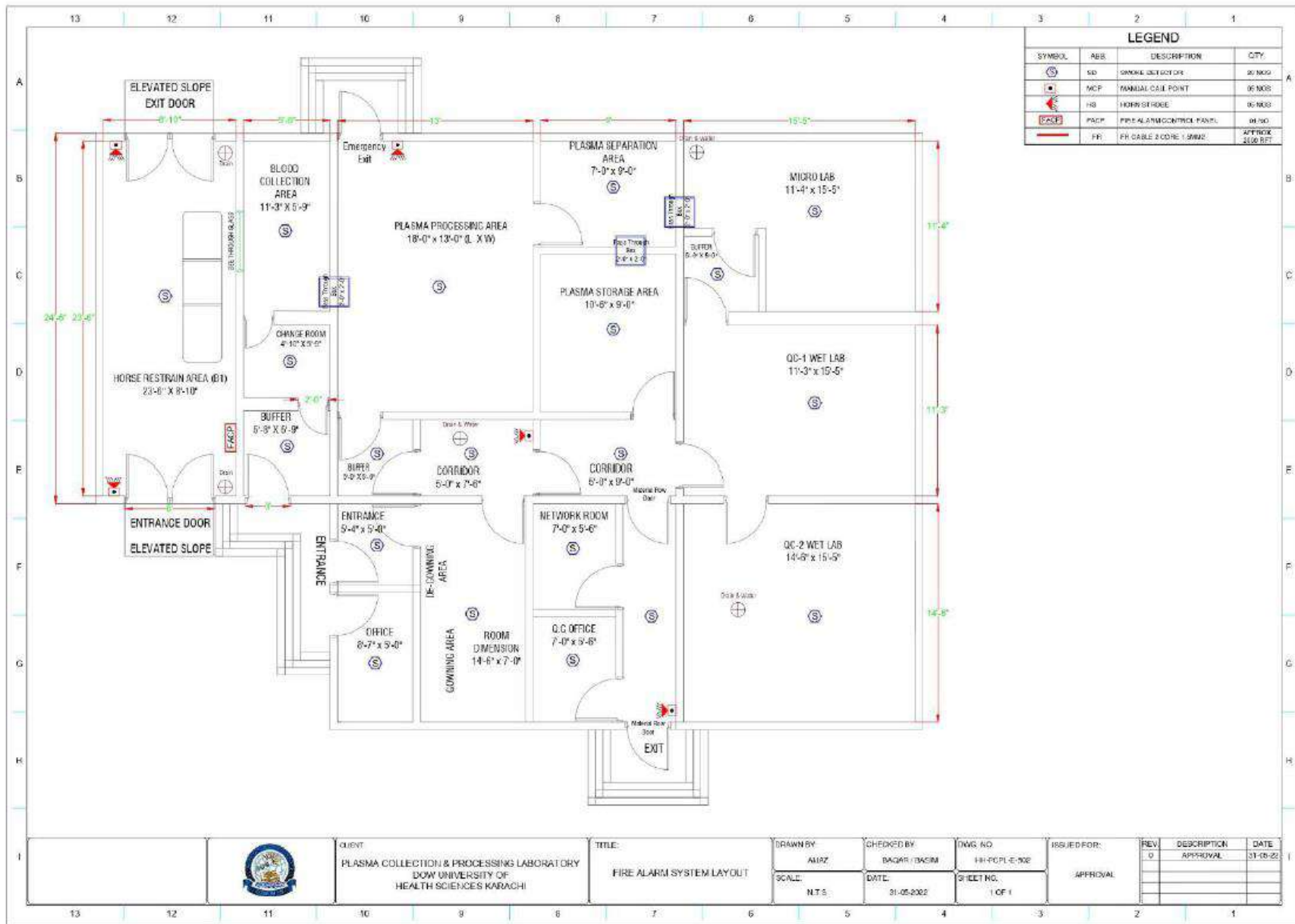

LEGEND			
SYMBOL	ABB.	DESCRIPTION	QTY.
(S)	SD	SMOKE DETECTOR	30 NOS
(MCP)	MCP	MANUAL CALL POINT	06 NOS
(HS)	HS	HORSE STABLE	06 NOS
(FACP)	FACP	FIRE ALARM CONTROL PANEL	01 NO.
(FR)	FR	FR CABLE 2 CORE 1 SWAZ	APPROX 5680 FT



CLIENT
PLASMA COLLECTION & PROCESSING LABORATORY
 DOW UNIVERSITY OF
 HEALTH SCIENCES KARACHI

TITLE:
FIRE ALARM SYSTEM LAYOUT

DRAWN BY:
 AHZ

CHECKED BY:
 BACAR / BASIM

DWG NO:
 141-PCPL-E-202

ISSUED FOR:
 APPROVAL

REV	DESCRIPTION	DATE
0	APPROVAL	31-05-22

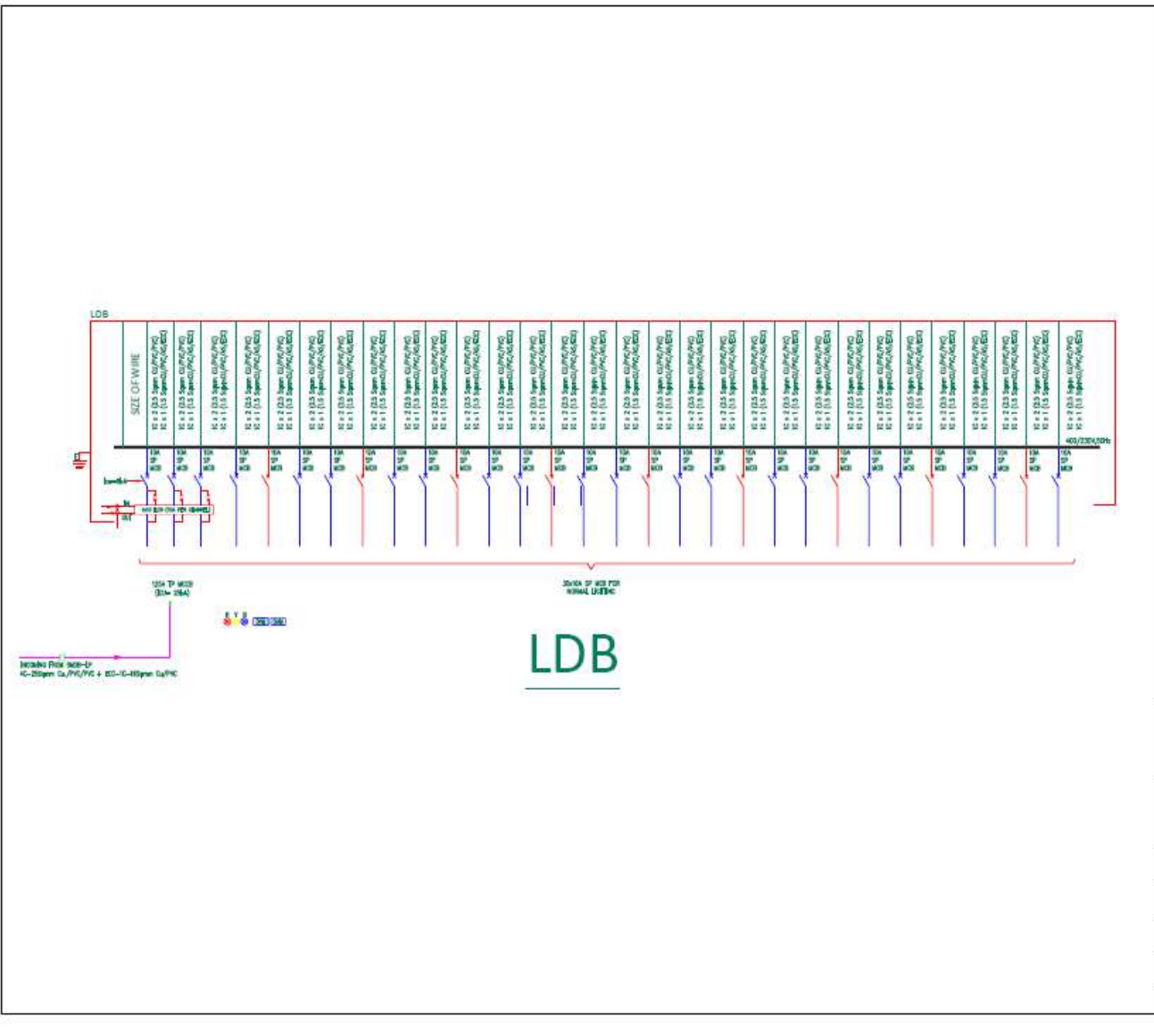

CLIENT

 PROJECT
 PLASMA COLLECTION AND PROCESSING LABORATORY

Approved By	RIZWAN	Sheet No.
Checked By	RIZWAN	DRAWING NO.
Drawn By	WARIS	
Scale	N.T.S	REVISION NO.
Date	ELECTRICAL SINGLE LINE DIAGRAM (LDB)	

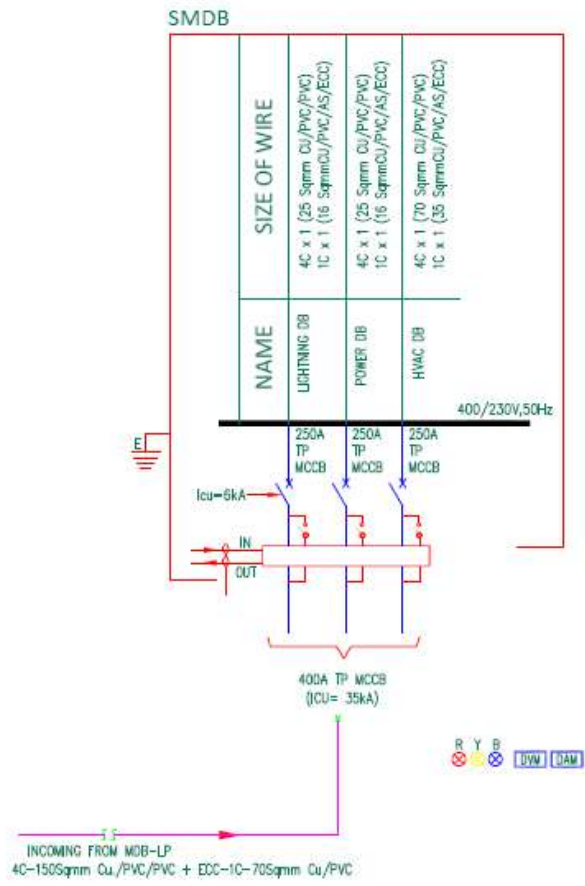

PDB

CLIENT		
 DOW UNIVERSITY <i>of HEALTH SCIENCES</i>		
PROJECT		
PLASMA COLLECTION AND PROCESSING LABORATORY		
Approved By	RIZWAN	Sheet No.
Checked By	RIZWAN	DRAWING NO.
Drawn By	WARIS	
Scale	N.T.S.	REVISION NO.
Date	ELECTRICAL SINGLE LINE DIAGRAM (PDB)	



SMDB

CLIENT		
PROJECT		
PLASMA COLLECTION AND PROCESSING LABORATORY		
Approved By	RIZWAN	Sheet No.
Checked By	RIZWAN	DRAWING NO.
Drawn By	WARIS	
Scale	N.T.S	REVISION NO.
Date	ELECTRICAL SINGLE LINE DIAGRAM (SMDB)	

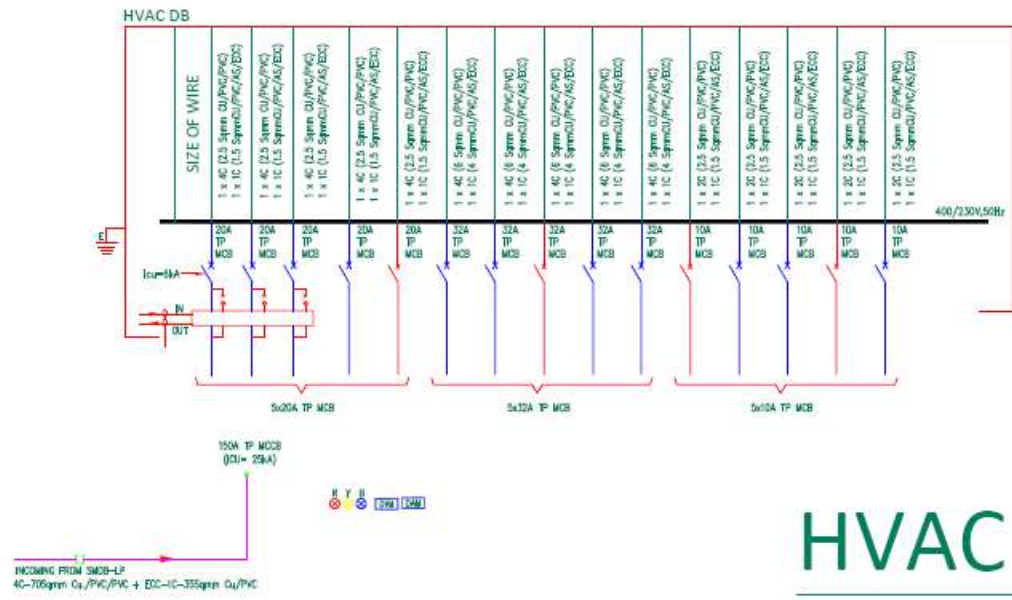

HVAC DB

CLIENT
DOW UNIVERSITY
of HEALTH SCIENCES

PROJECT
PLASMA COLLECTION AND PROCESSING LABORATORY

Approved By	RIZWAN	Sheet No.
Checked By	RIZWAN	DRAWING NO.
Drawn By	WARIS	
Scale	N.T.S	REVISION NO.
Date	ELECTRICAL SINGLE LINE DIAGRAM (HVAC DB)	